



City Council Meeting Agenda
Monday, December 18, 2023 – 6:30 p.m.
City Hall, 200 South Osage, Sedalia MO

MAYOR: ANDREW L. DAWSON

MAYOR PRO-TEM: RHIANNON M. FOSTER

- A. CALL TO ORDER** – Andrew L. Dawson – Council Chambers
- B. PRAYER & PLEDGE OF ALLEGIANCE**
- C. ROLL CALL**
- D. PUBLIC MEETING** – FY 2024-2025 Strategic Plan & Budget
- E. SPECIAL AWARDS/ SERVICE AWARDS/RETIREMENT AWARDS** – None
- I. APPROVAL OF PREVIOUS SESSION MINUTES**
 - A. Council Meeting – December 4, 2023
- II. REPORT OF SPECIAL BOARDS, COMMISSIONS AND COMMITTEES**
 - A. Acceptance of Citizen’s Traffic Advisory Commission minutes dated November 15, 2023
- III. ROLL CALL OF STANDING COMMITTEES**
 - A. PUBLIC SAFETY** - Chairman Jack Robinson; Vice Chairman Steve Bloess
 - 1. Presentation – Sedalia-Pettis County Emergency Management Agency (Trisha Rooda, Presenter)
 - B. FINANCE / ADMINISTRATION** – Chairman Chris Marshall; Vice Chairman Jack Robinson
 - 1. Presentation – Financial Update (Jessica Pyle, Presenter)
 - 2. Amending Garage Sale Permit Regulations
 - Council Discussion led by Chairman Marshall
 - Call for Ordinance Amending Chapter 44, Article III Rummage Sales of the Code of the City of Sedalia, Missouri to remove Garage Sale permitting – Mayor Dawson
 - 3. Ballot Question – Amending City Council Terms – 2 years to 4 years
 - Council Discussion led by Chairman Marshall
 - Call for Ordinance calling for a Special Election to be held in conjunction with the Municipal General Election to be held on April 2, 2024 to submit a proposal concerning increasing Terms for Council members from two years to four years – Mayor Dawson
 - 4. Amending Conflict of Interest Ordinance to reflect new position of Assistant City Administrator.
 - Council Discussion led by Chairman Marshall
 - Call for Ordinance Amending Section 2-833 (C) of Article IX of Chapter 2 of the Code of the City of Sedalia, Missouri to require Assistant City Administrator to file financial disclosure reports – Mayor Dawson
 - 5. Budget Amendment and quote – Vehicle Purchase – Assistant City Administrator - \$30,850.00
 - Council Discussion led by Chairman Marshall

R Call for Resolution of the City Council of the City of Sedalia, Missouri, stating facts and reasons for the necessity to amend and increase the City's annual budget for fiscal year 2024 – Mayor Dawson

O Call for Ordinance Amending the Budget for the Fiscal Year 2023-2024 and accepting a quote for vehicle purchase for Administration – Mayor Dawson

C. PUBLIC WORKS – Chairman Thomas Oldham; Vice Chairman Chris Marshall

1. Strategic Planning Presentation – Water & Wastewater (Chris Davies, Presenter)

2. Agreement – Rock Salt – Hutchinson Salt Company, Inc – Delivery \$75.42/Ton – Pickup \$41.13/Ton

Council Discussion led by Chairman Oldham

O Call for Ordinance Authorizing an agreement for Transport and Purchase of Rock Salt – Mayor Dawson

3. Presentation – Refuse Truck Purchases - \$757,800.00

Council Discussion led by Chairman Oldham

R Call for Resolution of the City Council of the City of Sedalia, Missouri, stating facts and reasons for the necessity to amend and increase the City's annual budget for fiscal year 2024 – Mayor Dawson

O Call for Ordinance Amending the Budget for the Fiscal Year 2023-2024 and approving and accepting a quote for the purchase of two side loader garbage trucks – Mayor Dawson

4. Budget Amendment and Ratification of rear load refuse truck purchase - \$267,364.95 (offset by Insurance proceeds of \$207,364.95)

Council Discussion led by Chairman Oldham

R Call for Resolution of the City Council of the City of Sedalia, Missouri, stating facts and reasons for the necessity to amend and increase the City's annual budget for fiscal year 2024 – Mayor Dawson

O Call for Ordinance Amending the Budget for the Fiscal Year 2023-2024 and ratifying the purchase of a rear load garbage truck and camera - Mayor Dawson

5. Annexation & Utility Services Agreement – Kroeger Property II, LLC – Connection to Water Distribution System – Properties located at 6025 Lowe Drive and 6027 Lowe Drive

Council Discussion led by Chairman Oldham

O Call for Ordinance Authorizing an Annexation and Utility Services Agreement for connection to the City of Sedalia's water distribution system – Mayor Dawson

O Call for Ordinance Authorizing an Annexation and Utility Services Agreement for connection to the City of Sedalia's water distribution system – Mayor Dawson

6. Task Order #2 – Burns and McDonnell – CWWTP Expansion - \$141,689.00

Council Discussion led by Chairman Oldham

O Call for Ordinance Authorizing Task Order Number Two for technical support and engineering Services related to the Central Wastewater Treatment Plant Expansion – Mayor Dawson

- D. **COMMUNITY DEVELOPMENT** – Chairwoman Rhiannon M. Foster; Vice Chairwoman Tina Boggess
- No Report

IV. **OTHER BUSINESS**

- A. **APPOINTMENTS** – None
- B. **LIQUOR LICENSES** – None

V. **MISCELLANEOUS ITEMS FROM MAYOR, CITY COUNCIL AND CITY ADMINISTRATOR**

VI. **GOOD AND WELFARE**

- VII. **Closed Door Meeting** – Motion and Second to move into closed door meeting in the upstairs conference room pursuant to Subsections 1 (Legal Advice), 2 (Real Estate), and 12 (Negotiated Contracts) of Section 610.021 RSMo.

- A. Roll Call Vote for Closed Door Meeting
- B. Discussion of closed items
- C. Vote on matters, if necessary (require a Roll Call Vote)
- D. Motion and Second with Roll Call Vote to adjourn closed door meeting and return to open meeting

VIII. **ADJOURN MEETING**

- A. Motion and second to adjourn meeting

Please join the meeting by clicking or touching this link from your smartphone, computer, tablet, or iPad:
<https://global.gotomeeting.com/join/578973061>

If this is the **first time** you have joined a GoToMeeting you will be asked to identify yourself. Please fill in this information. If you would like, and we suggest you do, go ahead and set your preferences to make it easier to join next time. If you are new to GoToMeeting? We suggest to get the app through the following link: <https://global.gotomeeting.com/install/578973061> This will make joining these meetings quick and easy. Once you have followed the link above and identified yourself you will be given options for how you want to join in with **audio**.

For **smartphones**: tap on one of the phone numbers and it will dial the phone and the meeting numbers.
For **other devices**: use the feature of call me. The phone audio will be much better than through your computer. This should come up if you have your preferences set up to show it. If it does not, in the upper right-hand corner of the GoToMeeting screen you will see an icon that looks like a gear. Click on the gear and then look for “Phone” and if it is not highlighted click on it. One of the options should be to call me. Put the phone number you want to be called on (direct dial) into the box provided and then click the “Call Me” button. Once the system calls you, you will be asked to hit pound.

Please be mindful of others on the call by eliminating as much background noise as you can. Mute yourself until you are ready to speak. Do not put the call on hold, if you need to leave even for a short time, hang up as you can always dial back in after your other call. If you hear an echo or squeal, you may have your computer speakers on as well as the phone, mute your computer speakers to eliminate this.

If you want to join in **listen only** mode you can dial the following number and enter the access code.

(For supported devices, tap a one-touch number below to join instantly.)

United States (Toll Free): 1 866 899 4679
- One-touch: <tel:+18668994679,,578973061#>

United States: +1 (669) 224-3318
- One-touch: <tel:+16692243318,,578973061#>

Access Code: 578-973-061

The City Council reserves the right to discuss any other topics that are broached during the course of this meeting.

IF YOU HAVE SPECIAL NEEDS, WHICH REQUIRE ACCOMMODATION, PLEASE NOTIFY THE CITY CLERK'S OFFICE AT 827-3000. ACCOMMODATIONS WILL BE MADE FOR YOUR NEEDS

POSTED ON DECEMBER 15, 2023, AT 3:30 P.M. AT THE SEDALIA MUNICIPAL BUILDING, BOONSLICK REGIONAL LIBRARY, SEDALIA PUBLIC LIBRARY AND ON THE CITY'S WEBSITE AT WWW.SEDALIA.COM

[Click on any agenda item to view the related documentation](#)



OFFICE OF THE CITY ADMINISTRATOR

To: Honorable Mayor Andrew L. Dawson & City Council Members
From: Kelvin Shaw, City Administrator 
Re: Agenda items for City Council meeting on Monday, December 18, 2023, 6:30 p.m.

Strategic Plan Input – As we progress through our strategic planning process heading to the January 6 session, we set aside a time each year to invite the public to provide input. Staff advertises this invitation to the public to provide suggestions at this time for inclusion in the strategic plan.

Public Safety Committee – There is one item for consideration through the Public Safety Committee.

1. As part of our strategic planning process, we ask that our outside service contractors make a presentation. The contract requires such presentation and essentially, we ask that they report on how the funds were used this fiscal year, and then what services and costs they propose for the next fiscal year. For this meeting Trisha Rooda, will make such a report of the cooperative contract between the City and County to join together for emergency management.

Finance/Administration Committee – There are five items for consideration through the Finance / Administration Committee.

1. Jessica Pyle, Finance Director, will provide an update on major trends in tax revenue collections.
2. Current City Code imposes certain regulations on holding garage sales and, in those regulations, imposes the requirement to obtain a permit for each such sale. The intent of the permitting requirement was to insure compliance with the regulations. However, many were not aware of the permit requirement and therefore never applied. Further, policing of the permits themselves has proven to be inefficient and unproductive to accomplishing the real intent of the regulations. Therefore, staff suggests eliminating the unwarranted and ineffective bureaucracy of the permit requirements. This still leaves the ability to manage the requirements, such as duration and frequency allowed, through other means that focuses solely on those that create a nuisance or undue disruption to the neighborhood. Staff recommends approval.
3. At the last Council meeting a very good discussion and debate on the merits of moving Council Member terms to four years was held. Ultimately, Council voted six in favor of and two against to direct staff to prepare an ordinance and bring back to this meeting for consideration to put this issue on a ballot for a vote of the people to weigh in. As stated during the discussion, staff sees this as purely a Council choice and has no recommendation for or against.
4. Certain positions within the City are required to make disclosures regarding potential conflicts of interest as regulated by the Missouri Ethics Commission (MEC) and City Codes. With the reinstatement of an Assistant City Administrator position, we asked legal to review if this position is subject to these disclosure reporting requirements. Our City Attorney advised that

the MEC reporting requirements do not apply to this position; however, the MEC does not preclude us from imposing these requirements by City Code. Therefore, in the spirit of transparency, full disclosure, and ensuring public trust, staff recommends imposing the conflicts of interest reporting requirements on the Assistant City Administrator position.

5. Included in the employment agreement with the Assistant City Administrator are provisions for, and limitations on the use of a city owned vehicle. We have located a used Durango that is suitable for this use from the Kansas Highway Patrol for \$30,850. Staff recommends approval of a budget amendment to appropriate the funds for this purchase.

Public Works Committee – There are five items for consideration through the Public Works Committee.

1. Chris Davies, our Public Works Director, will continue this year's presentations of strategic planning for each department. Director Davies will present at this meeting an overview of the plans for the water and wastewater departments.

As a reminder, I ask that in each of the individual presentations that they address the following four questions:

- a) Why is the service needed?
- b) Why should the City be doing it?
- c) What level of service are we providing now?
- d) How are we going to accomplish it? In other words, strategies going forward for services including any major budget requests related to new or expanded initiatives.

These presentations will all lead up to and set the stage for the Council strategic planning session on January 6th (the first Saturday in January). During this session, we review the highlights of each of these individual department strategic plans to bring them together into an overall plan for the City, to include setting relative priorities. This high-level direction from Council then becomes the basis for the budget development to match that strategy. We will then have budget work sessions February through March, culminating with a budget adoption the last meeting in March.

2. As part of our road maintenance program, we have a need for rock salt to treat roads during snow and ice events. We have developed storage capacity that enables us to bring in enough material to last the entire season, unless we have an extreme year with an abnormal number of events. This storage capacity allows us to bargain for a better lump sum price delivered outside of when everyone else is needing product. Likewise, this means that when it gets toward the end of the season and other communities are scrambling to find materials, we have it on hand. Staff has issued an invitation for bids (IFB) in accordance with our procurement policies. Four bids were received in response to the IFB and staff recommends award to the low bidder, Hutchinson Salt Company, Inc. at the bid price of \$75.42 per ton delivered price, and \$41.13 per ton with us picking it up.
3. The strategic plan for the upcoming year included the need to replace garbage trucks that are at the end of their useful lives. Further, the intent was to lay out the plan in the budget development for next fiscal year. However, we have been experiencing equipment failures at a rate that are impeding our ability to keep trash picked up. We have had so many failures at

the same time that we had to have public works crews pick up trash with loaders and dump trucks, which is inefficient to say the least. Likewise, the repair costs to keep the current trucks operational has been excessive and consuming our fleet maintenance resources. Therefore, staff has accelerated the proposal for Council consideration to move forward with some of the needed replacements now. The current operations require four side loaders and two rear loading trucks. This number allows for one of each type to be in reserve to rotate in as needed when others are down for maintenance or repairs. When we entered into a lease purchase arrangement five years ago for the side loaders, the intent was that these trucks had an expected useful life in excess of seven years. This would allow us to start purchasing replacements one at a time at the end of the five-year amortization so that we could get them spread out on a rotational replacement schedule. However, these trucks have proven to be undersized for our needs, and therefore have not lasted as long as they were anticipated to. Staff has researched and identified heavier trucks that are more suitable to the usage that we put them through, and further, have located two such trucks available for purchase now at \$757,800.00. Another part of the problem though, is that the Sanitation Fund does not have sufficient reserves to offset this level of purchase. I recommend that rather than going externally to borrow the funds or enter into a leasing arrangement, that we loan the money from the General Fund to cover this purchase. The General Fund has sufficient reserves to cover this without unduly putting into jeopardy the financial stability of the City even when considering fluctuations in the economy or the ability to react to disasters. As reported in our last audit report the General Fund has an unassigned fund balance of \$9,664,833. Staff recommends approval to move forward with this plan.

4. To further complicate matters with sanitation trucks discussed above, the newest rear loader truck was recently involved in an accident and the insurance adjuster determined it to be a total loss. We had two older trucks that we had been using as reserve when other trucks broke down. When the front-line new truck was wrecked, this put one of the older units back to front line use. Then the reserve unit went down and was not repairable, leaving us with no reserve on either the rear load or side load routes. This meant when any truck went down we had to bring in loaders and dump trucks. Staff worked with the insurance company to collect the proceeds from the totaled truck of \$207,364.95, and then located a new truck that was coming available quickly for \$265,000.00 plus \$2,364.95 to add camera equipment. Since we had a short window to secure the new truck, Mayor Dawson declared it an emergency purchase. In the spirit of transparency, staff recommends ratification of the purchase decision, as well as, approval of a budget amendment to formally appropriate the funds.
5. The owner of two lots, currently outside the city limits, has requested a connection to City utilities. In keeping with past practices over the last few years, staff has negotiated an annexation and utility services agreement. This agreement gives the City the right to annex the property at such time it becomes eligible, in exchange for providing access to City water services. Staff recommends approval of the two agreements with Kroeger Properties II LLC.

Community Development Committee-There are no items for consideration.

Notice of Public Meeting

A public meeting will be held at 6:30 p.m. on Monday, December 18, 2023 in the Council Chambers of the Municipal Building at 200 South Osage. At this time, citizens may be heard on items for consideration by Council in setting the strategic plan and budget for the fiscal year beginning April 1, 2024.

Run 1x
December 9, 2023



CITY OF SEDALIA, MISSOURI
CITY COUNCIL MEETING
DECEMBER 4, 2023

The City has an on-line broadcast of Council Meetings available both live and recorded by going to https://global.gotomeeting.com/join/578973061

The Council of the City of Sedalia, Missouri duly met on Monday, December 4, 2023 at 6:30 p.m. at the Municipal Building in the Council Chambers with Mayor Andrew L. Dawson presiding.

ROLL CALL:

Table with 4 columns: Name, Status (Present), Name, Status (Present). Rows include Jack Robinson, Thomas Oldham, Chris Marshall, Tina Boggess, Bob Hiller, Bob Cross, Rhiannon Foster, Steve Bloess.

SERVICE AWARDS:

Table with 4 columns: Award Type, Name, Title, Recipient. Rows include 10 Year Pin/Certificate (Jon Wilson, Equipment Operator II, Sanitation) and 5 Year Pin/Certificate (Ashley Beck, Circulation Supervisor, Library).

SPECIAL AWARDS/RETIREMENT AWARDS: - None

MINUTES: The Council Meeting minutes of November 20, 2023 were approved on motion by Foster, seconded by Cross. All in Favor.

UNFINISHED BUSINESS:

- The owner of Twilight Motors applied for a Special Use Permit for a car dealership business to be located on property at 204 East 24th Street. The item was postponed at the November 20, 2023 Council meeting due to carport placement that didn't meet setback requirements.

BILL NO. 2023-225, ORDINANCE NO. 11940 – AN ORDINANCE GRANTING A SPECIAL USE PERMIT TO NICHOLAS A. DILTHEY FOR A CAR DEALERSHIP BUSINESS ON PROPERTY LOCATED AT 204 EAST 24TH STREET IN THE CITY OF SEDALIA, MISSOURI was read once by title.

2nd Reading – Motion by Oldham, 2nd by Marshall. All in Favor.

Final Passage – Motion by Oldham, 2nd by Robinson. All in Favor.

Roll Call Vote: Voting "Yes" were Robinson, Oldham, Boggess, Hiller, Cross, Foster and Bloess. No one voted "No". Marshall abstained due to being related to one employee that moved the structure.

REPORTS OF SPECIAL BOARDS, COMMISSIONS & COMMITTEES: None

ROLL CALL OF STANDING COMMITTEES:

FINANCE & ADMINISTRATION – Chris Marshall, Chairman; Jack Robinson, Vice Chairman

Discussion: Consideration of moving Council to 4-Year Terms

City Council discussed changing Council Terms from 2 years to 4 years. City Prosecutor, Todd Smith explained that the term length process is defined by Statute 77.030. A city can move from 2 to 4-year terms which become effective on the next election. If approved by the voters, it would not be retroactive but the next term would be 4 years. There is a deadline of January 23, 2024 for adding the question to the April 2, 2024 ballot. The language on the ballot would read "Shall the terms of council members which are currently set at 2 years in the City of Sedalia, be extended 2 years for members elected after the relevant date".

Council Comments:

Oldham – Opposed to extension of terms; 2-year terms allow council members to remain active in the community and ensure they do their job appropriately and effectively; moving to 4-year terms has no benefit; believes in giving the voters the opportunity to have a say on the issue.

Bogges – In favor of increase to match Mayor term of 4-years; first 2 years is learning and then you return and run again; would be easier and more cohesive to have the extra time.

Hiller – Has received positive feedback from citizens and staff on extending City Council terms; first 1-2 years is learning the job.

Cross – By increasing the term, more individuals would be interested in running.

Foster – Pros and Cons to changing the term; would save taxpayer dollars by having fewer elections; shorter term encourages you to stay connected as a council member.

Bloess – Opposed to increase; willing to put it on ballot and let the voters decide.

Robinson – Opposed to increase; having the extra time is not beneficial; if you do a great job, you are re-elected.

Motion by Bogges, seconded by Cross to draft an ordinance for the December 18, 2023 Council meeting to put the language on the April ballot. Roll Call Vote: Voting "Yes" were Oldham, Marshall, Bogges, Hiller, Cross and Foster. Voting "No" were Robinson and Bloess.

PUBLIC SAFETY – Jack Robinson, Chairman; Steve Bloess, Vice Chairman

Strategic Planning Presentation – Fire Department

Fire Chief Matt Irwin provided the following statistics since 2017: 42.3% increase in incidents; 46.6% increase in EMS; 34.2% increase in Non-EMS; 7.82% increase in overlapping incidents; Response time increase of 42 seconds; Turnout time decrease of 19 seconds.

Accomplishments:

Fire Prevention: Inspections up 104%; Pre-incident planning averages 775 annually; Hydrant testing of approximately 1,000 Hydrants, or 300/month.

Training: Total hours up 256% (12,742). Hours per member average 296.

Department Budget Impact:

1. Stations – Central station rehabilitated 5 years ago but is due for replacement; possibility exists to add 610 acres to the southwest of the City; Future plans include Central Station rebuild behind the current Central Station along with a Training Center.

2. Apparatus - (2) squad trucks expected mid 2024; Engine expected mid-2024, recommend ordering 1 more; Aerial needs to be ordered in 2024, 3-year delivery; Brush Truck needs to be ordered.

3. **Personnel** - Full-time Training/Preparedness officer; increase daily staffing from 10 to 12 and per shift from 13 to 15.
4. **Training Facility** - Currently have one small Conex box which is not stamped or certified; new facility would give ability to conduct live fire training for state certification and offer training to other fire departments; approximate cost \$1 Million.
5. **Fire Hydrant Improvements** – Add hydrants to make inroads to underserved areas.
6. **EMS Improvements** – UTV; Ballistic vests and MCI Bags
7. **Community Involvement** - Freddie the Fire Truck, Digital Sign for Headquarters, First Due Community Connect, Off-Duty personnel for special events.

Presentation: Records Management System – Fire Department

Fire Chief Matt Irwin stated that the Fire Department currently uses Emergency Reporting by ESO and the company has since sold and will not support or update emergency reporting to meet NERIS standards. The software is needed because under the United States Fire Administration, they are required to report all fire incidents and it is required for the acceptance of Federal Grants.

In reviewing various vendors, **ESO** increased cost to \$15,620 annually with a \$4,160 implementation fee and no additional services. **Tyler Technologies** was \$12,912 annually with a \$15,785 implementation fee, however, it is more geared toward Police and Joint Communications and everything is 3rd party. **First Due** is one platform and meets all fire department needs. The cost is \$24,100 for 15 months. Councilman Bloess inquired about a community module. Fire Chief Irwin stated that it is part of the Community Risk reduction. The community connect section will provide information on people, pets, special needs individuals, etc. and information is “back facing”, meaning that it is not visible to the general public. The First Due system is efficient, saves time, provides cross module communication, vital information at time of dispatch, integrates with Brycer and direct connection with the community.

BILL NO. 2023-226, ORDINANCE NO. 11941 – AN ORDINANCE AUTHORIZING AN AGREEMENT FOR REPORT MANAGEMENT SOLUTIONS FOR THE SEDALIA FIRE DEPARTMENT was read once by title.

2nd Reading – Motion by Oldham, 2nd by Bloess. All in Favor.

Final Passage – Motion by Oldham, 2nd Robinson. All in Favor.

Roll Call Vote: Voting “Yes” were Robinson, Oldham, Marshall, Boggess, Hiller, Cross, Foster and Bloess. No one voted “No”.

Strategic Planning Presentation – Police Department

Police Chief Matthew Wirt and Commander David Woolery gave an overview of Police Department Operations and goals. Department services include police, community services and training. Year-to-date, the department has handled over 30,000 calls for service. The Traffic/DWI unit have worked together to reduce serious incidents by 23% over the past 3 years. The Drone unit currently has 6 licensed pilots and 3 additional officers are getting their license. The Department was able to secure a grant for 4 bicycles and 2 e-bikes to use on the Katy Trail or other areas that require a quiet or hands on approach. The Department is involved with 4th of July, Halloween, Thanksgiving eve events and increased social media presence.

Areas of training include West Point Leadership (3-week leadership intensive course designed by West Point military and geared toward law enforcement); Raider Training (high intensive/active shooter type

call); Emergency Vehicle Operation Course driver training for all officers; Regional CIT training; Specialized crime scene and investigation training; and in-service training.

Strategic Planning:

Police: Field Mobile Software – helps improve safety and efficiency for officer/command staff and allows access to real-time computer aided dispatch; call information instantly accessible to officers in the field; alerts officers to danger and provides situational awareness; Public Safety Analytics – provides method for extracting, analyzing and visualizing information to create actionable insights; Data Collect Mobile – eliminates human error and legibility issues through digital input, instantly shares data, efficiently accesses data anytime/anywhere; Electronic Crash Module – Ability to scan and import driver/vehicle data, capture and store photos and audio of crash scene, Information only needs gathered once, current module has announced end of support; Recruitment and Retention: provide highly competitive employee package for officers; continue hiring incentive program or paying for police academy; people are greatest asset and work to solve community problems; continue programs that provide for career growth; shot detection devices; License Plate Recognition to track vehicles involved in illegal drug/criminal enterprise; Community or neighborhood based cameras.

Community Services and Engagement: Engage community to solve problems through Problem Oriented Policing; public engagements with positive learning experiences and online presence; understand role of police within Community.

Future: Focus on recruitment and retention with valuing personnel; establish positive community relationships while solving problems; use innovative technology to do more with less and allow technology to improve efficiency of officers.

➤ The Budget Amendment and quotes are for Police Radio Purchases. Cost \$27,173.00.

RESOLUTION NO. 2071 – A RESOLUTION OF THE CITY COUNCIL OF THE CITY OF SEDALIA, MISSOURI, STATING FACTS AND REASONS FOR THE NECESSITY TO AMEND AND INCREASE THE CITY’S ANNUAL BUDGET FOR FISCAL YEAR 2024 was read once by title and approved on motion by Oldham, seconded by Foster. All in Favor.

BILL NO. 2023-227, ORDINANCE NO. 11942 – AN ORDINANCE AMENDING THE BUDGET FOR THE FISCAL YEAR 2023-2024 AND APPROVING QUOTES FOR POLICE RADIO PURCHASES was read once by title.

2nd Reading – Motion by Oldham 2nd by Robinson. All in Favor.

Final Passage – Motion by Oldham, 2nd by Robinson. All in Favor.

Roll Call Vote: Voting “Yes” were Robinson, Oldham, Marshall, Boggess, Hiller, Cross, Foster and Bloess.

No one voted “No”.

PUBLIC WORKS – Thomas Oldham, Chairman; Chris Marshall, Vice Chairman

➤ The agreement with ArborPro is for tree re-inventory of approximately 2,006 City Park and Right-of-way trees. Cost \$7,923.70.

BILL NO. 2023-228, ORDINANCE NO. 11943 – AN ORDINANCE AUTHORIZING AN AGREEMENT FOR A TREE RE-INVENTORY OF APPROXIMATELY 2,006 CITY PARK AND RIGHT-OF-WAY TREES was read once by title.

2nd Reading – Motion by Oldham, 2nd by Foster. All in Favor.

Final Passage – Motion by Oldham, 2nd by Robinson. All in Favor.

Roll Call Vote: Voting “Yes” were Robinson, Oldham, Marshall, Boggess, Hiller, Cross, Foster and Bloess.

No one voted “No”.

➤ The Budget amendment and new job classification and description are for Part-time Flight Instructor and plane rental.

RESOLUTION NO. 2072 – A RESOLUTION OF THE CITY COUNCIL OF THE CITY OF SEDALIA, MISSOURI, STATING FACTS AND REASONS FOR THE NECESSITY TO AMEND AND INCREASE THE CITY'S ANNUAL BUDGET FOR FISCAL YEAR 2024 was read once by title and approved on motion by Oldham, seconded by Robinson. All in Favor.

BILL NO. 2023-229, ORDINANCE NO. 11944 – AN ORDINANCE AMENDING THE BUDGET FOR THE FISCAL YEAR 2023-2024 AND ADDING A NEW CLASSIFICATION AND JOB DESCRIPTION REGARDING AIRPORT FLIGHT INSTRUCTOR AND PLANE RENTAL was read once by title.

2nd Reading – Motion by Oldham, 2nd by Robinson. All in Favor.

Final Passage – Motion by Oldham, 2nd by Marshall. All in Favor.

Roll Call Vote: Voting "Yes" were Robinson, Oldham, Marshall, Boggess, Hiller, Cross, Foster and Bloess.

No one voted "No".

COMMUNITY DEVELOPMENT – Rhiannon M. Foster, Chairwoman; Tina Boggess, Vice Chairwoman

➤ At the November 20, 2023 City Council meeting, a public hearing was held to hear any comments regarding the annexation petition from Highway H Property, LLC for property along HH at the north edge of town. No comments have been received and Council may now consider an Ordinance.

BILL NO. 2023-230, ORDINANCE NO. 11945 – AN ORDINANCE OF THE CITY OF SEDALIA, MISSOURI, APPROVING AND ANNEXING AN UNINCORPORATED AREA OWNED BY HIGHWAY H PROPERTY, LLC, INTO THE CITY OF SEDALIA, MISSOURI, ADJACENT AND CONTIGUOUS TO EXISTING CORPORATE LIMITS OF SAID CITY was read once by title.

2nd Reading – Motion by Oldham, 2nd by Robinson. All in Favor.

Final Passage – Motion by Foster, 2nd by Oldham. All in Favor.

Roll Call Vote: Voting "Yes" were Robinson, Oldham, Marshall, Boggess, Hiller, Cross, Foster and Bloess.

No one voted "No".

➤ After adoption of the animal code, it became apparent that some items needed attention. First item was that the code allowed certain animals to be kept in zones marked agricultural while the zoning code does not contain provisions to zone areas as agricultural. The second item references allowing private stables, which created conflicting language between zoning code and the animal code.

BILL NO. 2023-231, ORDINANCE NO. 11946 – AN ORDINANCE OF THE CITY OF SEDALIA AMENDING CITY CODE REGARDING ANIMALS was read once by title.

2nd Reading – Motion by Oldham, 2nd by Foster. All in Favor.

Final Passage – Motion by Oldham, 2nd by Robinson. All in Favor.

Roll Call Vote: Voting "Yes" were Robinson, Oldham, Marshall, Boggess, Hiller, Cross, Foster and Bloess.

No one voted "No".

APPOINTMENTS: None

BIDS: Tree Re-Inventory – November 21, 2023

LIQUOR LICENSES: The following renewal Liquor License was read and approved on motion by Oldham, seconded by Foster. All in Favor.

Renewal:

*Adam McMillin dba Walmart Store No. 219, 3201 West Broadway, Packaged Liquor & Sunday Sales

MISCELLANEOUS ITEMS FROM MAYOR/COUNCIL/ADMINISTRATOR:

Mayor Dawson congratulated Councilman Oldham on the birth of his first child.

City Administrator, Kelvin Shaw thanked the Furnell’s for the Thanksgiving Day Fireworks and also commented that that the Christmas parade was great.

Councilman Cross commented that the City needs to look at having a Full-Time Mayor.

GOOD & WELFARE: None

The meeting adjourned at 8:20 p.m. on motion by Oldham, seconded by Foster to a closed-door meeting in the upstairs conference room pursuant to subsections 1 (Legal Advice), 2 (Real Estate), 3 (Personnel), and 12 (Negotiated Contracts) of Section 610.021 RSMo. Roll Call Vote: Voting “Yes” were Robinson, Oldham, Marshall, Boggess, Hiller, Cross, Foster and Bloess. No one voted “No”.

The regular meeting reopened at 9:46 p.m. on motion by Foster, seconded by Oldham. All in favor.

Jack Robinson	Present	Bob Hiller	Present
Thomas Oldham	Present	Bob Cross	Present
Chris Marshall	Present	Rhiannon Foster	Present
Tina Boggess	Present	Steve Bloess	Present

BUSINESS RELATED TO CLOSED DOOR MEETING:

BILL NO. 2023-232, ORDINANCE NO. 11947 – AN ORDINANCE APPROVING A SPECIAL WARRANTY DEED FOR THE SALE OF PROPERTY ON SEDALIA ROAD FROM THE CITY OF SEDALIA, MISSOURI TO BROKEN ARROW PROPERTIES, LLC, A MISSOURI LIMITED LIABILITY COMPANY was read once by title.

2nd Reading – Motion by Oldham, 2nd by Robinson. All in favor.

Final Passage – Motion by Oldham, 2nd by Robinson. All in favor.

Roll Call Vote: Voting “Yes” were Robinson, Oldham, Marshall, Boggess, Hiller, Cross, Foster and Bloess. No one voted “No”.

BILL NO. 2023-233, ORDINANCE NO. 11948 – AN ORDINANCE APPROVING A SPECIAL WARRANTY DEED FOR THE SALE OF PROPERTY COMMONLY KNOWN AS 916 SOUTH OHIO AVENUE FROM THE CITY OF SEDALIA, MISSOURI TO KROEGER PROPERTIES II, A MISSOURI LIMITED LIABILITY COMPANY was read once by title.

2nd Reading – Motion by Oldham, 2nd by Marshall. All in favor.

Final Passage – Motion by Oldham, 2nd by Foster. All in favor.

Roll Call Vote: Voting “Yes” were Robinson, Oldham, Marshall, Boggess, Hiller, Cross, Foster and Bloess. No one voted “No”.

BILL NO. 2023-234, ORDINANCE NO. 11949 – AN ORDINANCE AMENDING CITY CODE AND ADDING A NEW CLASSIFICATION AND JOB DESCRIPTION FOR ASSISTANT CITY ADMINISTRATOR AND A RELATED AMENDMENT TO AN EXISTING JOB DESCRIPTION FOR CITY ADMINISTRATOR FOR THE CITY OF SEDALIA, MISSOURI was read once by title.

2nd Reading – Motion by Oldham, 2nd by Marshall. All in favor.

Final Passage – Motion by Oldham, 2nd by Robinson. All in favor.

Roll Call Vote: Voting “Yes” were Robinson, Oldham, Marshall, Boggess, Hiller, Cross, Foster and Bloess. No one voted “No”.

BILL NO. 2023-235, ORDINANCE NO. 11950 – AN ORDINANCE AUTHORIZING AN AGREEMENT BY AND BETWEEN THE CITY OF SEDALIA, MISSOURI AND MATTHEW WIRT was read once by title.

2nd Reading – Motion by Oldham, 2nd by Foster. All in favor.

Final Passage – Motion by Foster, 2nd by Oldham. All in favor.

Roll Call Vote: Voting “Yes” were Robinson, Oldham, Marshall, Boggess, Hiller, Cross, Foster and Bloess.
No one voted “No”.

RESOLUTION NO. 2073 – A RESOLUTION OF THE CITY COUNCIL OF THE CITY OF SEDALIA, MISSOURI, CONSENTING TO AND APPROVING THE APPOINTMENT OF DAVID WOOLERY AS INTERIM CHIEF OF POLICE FOR THE CITY OF SEDALIA, MISSOURI was read once by title and approved on motion by Oldham, seconded by Marshall. All in Favor.

The regular meeting adjourned at 9:50 p.m. on motion by Oldham, seconded by Marshall. All in favor.

THE CITY OF SEDALIA, MISSOURI

Andrew L. Dawson, Mayor

Jason S. Myers, City Clerk

TRAFFIC ADVISORY COMMISSION MEETING

November 15, 2023

The Traffic Advisory Commission duly met on Wednesday, November 15, 2023 at 12:00 p.m. at the City of Sedalia Municipal Building. The meeting was called to order by Chairman Esquivel.

ROLL CALL:

Members		Ex-Officio Members	
Deidre Esquivel	Present	AJ Silvey	Not Present
James Callis	Present	Matt Irwin	Present
John Rucker	Present	Chris Davies	Present
Dennis Henderson	Not Present		
Byron Matson	Present	Secretary	Elizabeth Nations
Sherry Broyles	Present		
Charles Leftwich	Present		

Minutes from the October 11, 2023 meeting were approved.

Guests: Police Chief Matt Wirt, Police Patrol Commander Adam Hendricks, Chief Office Administrator Tina Zaremba, Joleigh Cornine, Planner/Downtown Specialist and Mike Ingram.

OLD BUSINESS:

Availability of Handicap Parking Downtown

The Sedalia Main Streets Committee did approve the meeting minutes to move forward with the proposed number of handicap spots and their placement (see attached map). The Commission would now like to move forward with mailing letters to business/property owners in order to formally notify them of the planned addition of the handicap spots so their input on the matter can be given.

Mr. Matson made the motion for the request to remain tabled in order for the letters to be sent and the business/property owner's input can be given. Ms. Broyles seconded. All were in favor.

Traffic Counts-Winchester Dr.

Mr. Callis had requested traffic counts be conducted on Winchester Dr. between W. 10th St. to W. 16th St. in order to see how fast the vehicles are traveling in order to see if the speed limit should be increased. The traffic counts were completed but the summary has not been completed. The traffic count summary will be presented at the December meeting.

Mr. Callis motioned to table the request until the summary can be completed. Ms. Broyles seconded. All were in favor.

NEW BUSINESS:

Designate Loading/Unloading Zone at 103 S. Kentucky Ave.

Ashley Shane, Co-Owner of Main Street Logo, is requesting two parking spaces by 103 S. Kentucky Ave. be designated as a loading/unloading zone. They periodically have equipment to load and unload out of the door. Mike Ingram from Main Street Logo was in attendance and stated there is an employee at Katy Trail Health who parks in front of the door which limits access to the door. They have spoken to the employee and the manager to see if they could park elsewhere but they continue to park there. Daniel Powers, 219 W. Main St., is also interested in this designation.

Mr. Ingram said he would be interested in no parking, but then they would also not have access to the door to load/unload. Mr. Ingram also asked about authorized parking but those designations are not currently used in the City of Sedalia.

Mr. Davies stated Public Works could paint the lines when time was available to mark the spaces.

Mr. Ingram stated he would talk to Mr. Powers and Ms. Shane to see what options they would like to pursue.

Mr. Callis motioned to table the request until the owners discuss what they would like to do. Mr. Leftwich seconded. All were in favor.

OTHER ITEMS FOR DISCUSSION:

None

The next meeting date is December 13, 2023.

The meeting adjourned at 12:24 p.m.

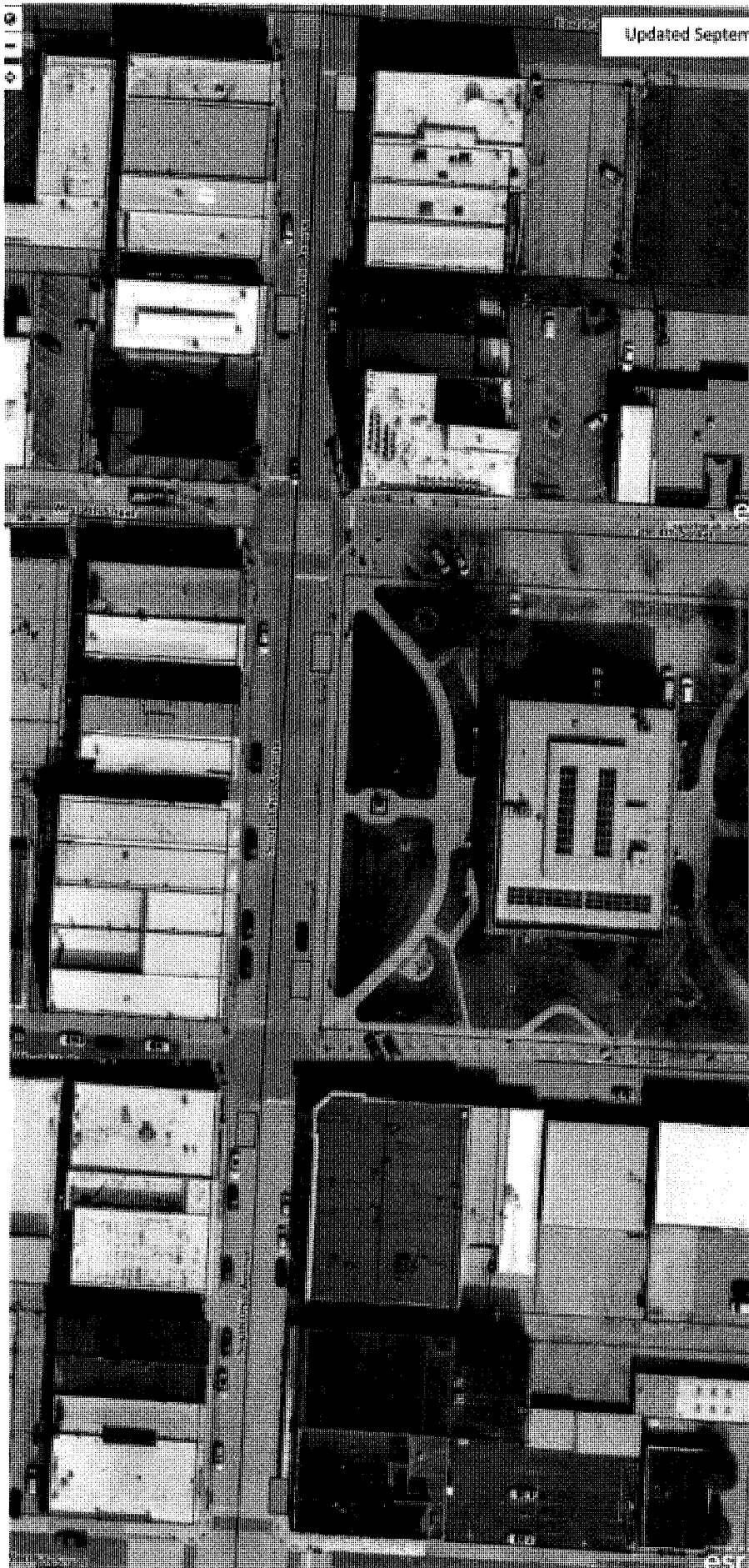

BILL NO. _____

ORDINANCE NO. _____

AN ORDINANCE AMENDING CHAPTER 44, ARTICLE III RUMMAGE SALES OF THE CODE OF THE CITY OF SEDALIA, MISSOURI TO REMOVE GARAGE SALE PERMITTING.

WHEREAS, the City of Sedalia, Missouri desires to remove permitting requirements for garage or rummage sales; and

WHEREAS, the City of Sedalia, Missouri has determined that it is appropriate and necessary to amend Chapter 44 to reflect the changes to garage sale regulations.

NOW THEREFORE, BE IT ORDAINED BY THE COUNCIL OF THE CITY OF SEDALIA, MISSOURI as follows:

Section 1. That **Chapter 44, Article III Rummage Sales** of the Code of the City of Sedalia, Missouri, be repealed in its entirety, and a new **Chapter 44, Article III Garage Sales** is hereby enacted to read as follows:

“ARTICLE III. GARAGE SALES

Sec. 44-88. Definitions.

A. As used in this Article, the term “Garage Sale” shall mean the sale or trade, or offering for sale or trade, of unwanted or surplus goods, wares, merchandise or personal property of a household nature to the general public held on the premises of a private single-family or multiple family residence or any other building by the owner, owners, tenants or occupants thereof. The term “garage sale” shall include, but not be limited to, any patio sales, rummage sales, yard sales, lawn sales, moving sales, or other sales similarly conducted at or upon any property. The term “Garage Sale” specifically does not include privately organized, occasional sales or trades of items of personal property to a private individual in a single transaction. The term “Garage Sale” also does not include no-impact home-businesses under 71.990 RSMo..

B. As used in this Article, the term “Estate Sale” shall mean a Garage Sale put on by the executor, administrator, or guardian of the legal estate of a deceased person.

Sec. 44-89. Frequency and duration; exceptions.

No Garage Sale shall be held or scheduled for more than two calendar days. No one person shall hold a Garage Sale more often than three times in any one calendar year; nor shall any such sale be held on the same premises more often than three times in any one calendar year unless otherwise explicitly authorized by law, provided, that this section shall not apply to any person conducting any such sale under and pursuant to a valid merchant's license issued by the city, nor to any Estate Sale.

Sec. 44-90. Exceptions for certain organizations.

The following organizations may have up to four Garage Sales per year on the same or different premises, provided that such premises are owned by the organization, or are not zoned R-1 to R-3 inclusive, nor used as residential property:

- (1) Organizations operating under section 501 of the Internal Revenue Code of the United States;
- (2) Not-for-profit corporations operating under state statutes; or
- (3) Organizations registered with the attorney general of the state under RSMo 407.453 et seq., charitable solicitations. Any such organization desiring to have more than two Garage Sales per year must provide adequate proof that they meet the requirements set forth in this section before the additional Garage Sales will be permitted.

Sec. 44-91. – Enforcement.

Violations of this Article are subject to municipal citation and prosecution. The penalty for violation shall be a fine as provided by law. Photographic evidence of garage sales on specific dates at specific locations, while not required, shall be admissible at trial as a business record of Sedalia Code Enforcement to prove the violation.

Secs. 44-92—44-125. Reserved”

Section 2. That Appendix A, City Fee Schedule, of the Code of the City of Sedalia, Missouri be amended to repeal, **Section 44-120 –Rummage, yard, or garage sale permit**, in its entirety.

Section 3. That the Fine/Bond Schedule of the City of Sedalia, Missouri be amended to repeal **Section 44-120 – No garage/rummage sale permit**, in its entirety.

Section 4. That all other parts and provisions of the City Code not in conflict herewith shall remain in full force and effect unless previously or subsequently amended or appealed.

Section 5. That should any section, sentence or clause of this Ordinance be declared invalid or unconstitutional, such declaration shall not affect the validity of the remaining sections, sentences, or clauses.

Section 6. That this Ordinance shall be in full force and effect beginning on January 1, 2024.

Section 7. That the City Clerk is authorized by this ordinance to correct any scrivener's errors identified within this Ordinance.

Read two times by title, copies of the proposed ordinance having been made available for public inspection prior to the time the bill is under consideration by the Council and passed by the Council of the City of Sedalia, Missouri this 18th day of December, 2023.

Presiding Officer of the Council

Approved by the Mayor of said City this 18th day of December, 2023.

Andrew L. Dawson, Mayor

ATTEST:

Jason S. Myers
City Clerk

To: Kelvin Shaw
From: Jason Myers & Devin Lake
Date: December 6, 2023
Subject: Rummage Sale Ordinance Revision

The attached revised ordinance allows for the removal of the permit requirement for rummage/garage sales. Due to the decreasing number of these no-cost permits over the last 10 years, and the administrative time that it takes to write them, we suggest that no permit be required as of January 1, 2024.

All other regulations, including the frequency and duration of such sales, will remain and will be enforced by Code Enforcement on a complaint or visual observation basis.

Thank you.

BILL NO. _____

ORDINANCE NO. _____

AN ORDINANCE CALLING FOR A SPECIAL ELECTION TO BE HELD IN CONJUNCTION WITH THE MUNICIPAL GENERAL ELECTION TO BE HELD ON APRIL 2, 2024 TO SUBMIT A PROPOSAL CONCERNING INCREASING TERMS FOR COUNCIL MEMBERS FROM TWO YEARS TO FOUR YEARS.

NOW THEREFORE, BE IT ORDAINED BY THE COUNCIL OF THE CITY OF SEDALIA, MISSOURI as follows:

Section 1. The City Council finds it desirable to submit a proposal to the qualified voters of the City of Sedalia, Missouri concerning increasing terms for Council Members from two years to four years as provided in Section 77.030 RSMo.

Section 2. A special election is hereby ordered to be held in the City of Sedalia, Missouri, in conjunction with the municipal general election on April 2, 2024, on the following question:

QUESTION

“Shall the terms of council members which are currently set at two years in the City of Sedalia, Missouri be extended to four years for members elected after April 2, 2024?”

Section 3. The form of the Notice of Election for said election, a copy of which is attached hereto and made a part hereof, is hereby approved.

Section 4. The City Clerk is hereby authorized and directed to notify the County Clerk of Pettis County, Missouri of the adoption of this Ordinance no later than 5:00 P.M. on January 23, 2024, and to include in said notification all of the terms and provisions required by Chapter 115 of the Revised Statutes of Missouri, as amended.

Section 5. This Ordinance shall be in full force and effect from and after its passage.

Read two times by title, copies of the proposed ordinance having been made available for public inspection prior to the time the bill is under consideration by the Council and passed by the Council of the City of Sedalia, Missouri this 18th day of December, 2023.

Presiding Officer of the Council

Approved by the Mayor of said City this 18th day of December, 2023.

Andrew L. Dawson, Mayor

ATTEST:

Jason S. Myers
City Clerk

NOTICE OF SPECIAL ELECTION

CITY OF SEDALIA, MISSOURI

Notice is hereby given to the qualified voters of the City of Sedalia, Missouri, that the City Council of the City has called a special election to be held in the City in conjunction with the municipal general election on April 2, 2024, commencing at 6:00 A.M. and closing at 7:00 P.M., on the question contained in the following sample ballot:

OFFICIAL BALLOT

CITY OF SEDALIA, MISSOURI

APRIL 2, 2024

QUESTION

“Shall the terms of council members which are currently set at two years in the City of Sedalia, Missouri be extended to four years for members elected after April 2, 2024?”

YES
NO

INSTRUCTIONS TO VOTERS: If you are in favor of the question, place an X in the box opposite “YES.” If you are opposed to the question, place an X in the box opposite “NO.”

The election will be held at the following polling places in the City:

PRECINCT

POLLING PLACE

DATED: _____, 2024.

Nick La Strada
County Clerk of Pettis County, Missouri

BILL NO. _____

ORDINANCE NO. _____

AN ORDINANCE AMENDING SECTION 2-833(C) OF ARTICLE IX OF CHAPTER 2 OF THE CODE OF THE CITY OF SEDALIA, MISSOURI TO REQUIRE ASSISTANT CITY ADMINISTRATOR TO FILE FINANCIAL DISCLOSURE REPORTS.

WHEREAS, the City of Sedalia, Missouri is authorized by 105.485, RSMo. to enact an ordinance which requires certain city officials and employees to file annual financial disclosure forms; and

WHEREAS, the City of Sedalia, Missouri currently requires each elected official, candidate for elective office, the chief administrative officer, the chief purchasing officer, and the full-time general counsel to file annual financial disclosure forms; and

WHEREAS, the City Council of the City of Sedalia, Missouri has determined that it is in the best interest of the citizens and City to require the Assistant City Administrator, the assistant administrative officer, to file annual financial disclosure forms.

NOW THEREFORE, BE IT ORDAINED BY THE COUNCIL OF THE CITY OF SEDALIA, MISSOURI as follows:

Section 1. That **Section 2-833(c)** of **Article IX — ETHICS, of Chapter 2 — Administration** of the Code of the City of Sedalia, Missouri, be amended to include additional language, to read as follows:

“(c) Disclosure reports. Each elected official, candidate for elective office, the chief administrative officer, **the assistant administrative officer**, the chief purchasing officer, and the full-time general counsel shall disclose the following information by May 1, or the appropriate deadline as referenced in RSMo 105.487, if any such transactions occurred during the previous year calendar year:

(1) For such person, and all persons within the first degree of consanguinity or affinity of such person, the date and the identities of the parties to each transaction with a total value in excess of \$500.00, if any, that such person had with the political subdivision, other than compensation received as an employee or payment of any tax, fee or penalty due to the political subdivision, and other than transfers for no consideration to the political subdivision.

(2) The date and the identities of the, parties to each transaction known to the person with a total value in excess of \$500.00, if any, that any business entity in which such person had a substantial interest, had with the political subdivision, other than payment of any tax, fee or penalty due to the political subdivision or transactions involving payment for providing utility service to the political subdivision, and other than transfers for no consideration to the political subdivision.

(3) The chief administrative officer, **the assistant administrative officer**, the chief purchasing officer and candidates for either of these positions also shall disclose by May 1, or the appropriate deadline as referenced in RSMo 105.487, the following information for the previous calendar year:

a. The name and address of each of the employers of such person from whom income of \$1,000.00 or more was received during the year covered by the statement.

b. The name and address of each sole proprietorship that he owned; the name, address and the general nature of the business conducted of each general partnership and joint venture in which he was a partner or participant; the name and address of each partner or co-participant for each partnership or joint venture unless such names and addresses are filed by the partnership or joint venture with the secretary of state; the name, address and general nature of the business conducted of any closely held corporation or limited partnership in which the person owned ten percent or more of any class of the outstanding stock or limited partnership units, and the name of any publicly traded corporation or limited partnership that is listed on a regulated stock exchange or automated quotation system in which the person owned two percent or more of any class of outstanding stock, limited partnership units or other equity interests;

c. The name and address of each corporation for which such person served in the capacity of a director, officer or receiver.”

Section 2. That all other parts and provisions of the City Code not in conflict herewith shall remain in full force and effect unless previously or subsequently amended or repealed.

Section 3. That should any section, sentence or clause of this Ordinance be declared invalid or unconstitutional, such declaration shall not affect the validity of the remaining sections, sentences, or clauses.

Section 4. That this Ordinance shall be in full force and effect from and after its passage and approval.

Section 5. That the City Clerk is authorized by this ordinance to correct any scrivener’s errors identified within this Ordinance.

Read two times by title, copies of the proposed ordinance having been made available for public inspection prior to the time the bill is under consideration by the Council and passed by the Council of the City of Sedalia, Missouri this 18th day of December, 2023.

Presiding Officer of the Council

Approved by the Mayor of said City this 18th day of December, 2023.

Andrew L. Dawson, Mayor

ATTEST:

Jason S. Myers
City Clerk

**CITY COUNCIL
OF THE CITY OF SEDALIA, MISSOURI**

RESOLUTION NO. _____

**A RESOLUTION OF THE CITY COUNCIL OF THE CITY OF SEDALIA, MISSOURI,
STATING FACTS AND REASONS FOR THE NECESSITY TO AMEND AND INCREASE
THE CITY'S ANNUAL BUDGET FOR FISCAL YEAR 2024.**

WHEREAS, Section 67.010 of the Revised Statutes of Missouri requires each political subdivision of the State of Missouri ("State") to prepare an annual budget and establishes the requirements for that budget; and

WHEREAS, the City of Sedalia, Missouri ("City"), is a city of the third classification created pursuant to Chapter 77, RSMo, and is a political subdivision of the State of Missouri; and

WHEREAS, the City Council of the City adopted and approved the City's annual budget for Fiscal Year 2023 in accordance with the requirements of Section 67.010, RSMo, by Ordinance No. 11535 on March 21, 2022, and

WHEREAS, Sections 67.030 and 67.040 authorize and provide a procedure for the City Council to amend the City's annual budget to increase expenditures in any fund; and

WHEREAS, expenses for City's operations for Fiscal Year 2024 have been higher than budgeted, but do not exceed revenues plus the City's unencumbered balance brought forward from previous years; and

WHEREAS, the City Council of the City desire to state the facts and reasons necessitating an amendment to increase certain expenditures in the Fiscal Year 2024 annual budget.

NOW THEREFORE, BE IT RESOLVED BY THE CITY COUNCIL OF THE CITY OF SEDALIA, MISSOURI, AS FOLLOWS:

Section 1. Expenditures from the City's General Fund must be increased by a total of \$30,850 above the amount authorized in the adopted annual budget for Fiscal Year 2024. An amendment to increase said budget is necessary for the following facts and reasons:

- A. Purchase vehicle for Administration.

Section 2. This Resolution shall take effect immediately upon its execution by the Mayor or otherwise as provided by law.

PASSED by the City Council of the City of Sedalia, Missouri, on December 18, 2023

Presiding Officer of the Council

ATTEST: _____
Jason S. Myers, City Clerk

BILL NO. _____

ORDINANCE NO. _____

**AN ORDINANCE AMENDING THE BUDGET FOR THE FISCAL YEAR 2023-2024
AND ACCEPTING A QUOTE FOR VEHICLE PURCHASE FOR ADMINISTRATION.**

**NOW THEREFORE, BE IT ORDAINED BY THE COUNCIL OF THE CITY OF
SEDALIA, MISSOURI** as follows:

Section 1. The 2023-2024 fiscal year budget beginning April 1, 2023 and ending March 31, 2024 is hereby amended to modify certain budgeted line items as they appear on the attached schedule and made a part hereof as Exhibit A as if fully set out herein.

Section 2. The City Council of Sedalia, Missouri hereby approves and accepts the quote by and between the City of Sedalia, Missouri and the Kansas State Highway Patrol and shall pay the total sum and amount of Thirty Thousand Eight Hundred Fifty Dollars (\$30,850.00) as more fully described in the quote attached to this Ordinance and incorporated by reference herein.

Section 3. The Mayor or City Administrator are authorized and directed to execute and the City Clerk is hereby authorized and directed to attest and fix the seal of the City of Sedalia, Missouri on the quote in substantively the same form and content as the quote have been proposed.

Section 4. This ordinance shall be in full force and effect from and after its passage and approval.

Read two times by title, copies of the proposed ordinance having been made available for public inspection prior to the time the bill is under consideration by the Council and passed by the Council of the City of Sedalia, Missouri this 18th day of December 2023.

Presiding Officer of the Council

Approved by the Mayor of said City this 18th day of December 2023.

Andrew L. Dawson, Mayor

ATTEST:

Jason S. Myers
City Clerk

Exhibit A
 City of Sedalia
 FY24 Budget Amendment 12/18/2023 Admin Vehicle Purchase

Account / Description	Current Budget	Change	Amended Budget	Comments
-----------------------	----------------	--------	----------------	----------

Revenues / Source of Funds

Expenditures / Uses of Funds

10-55-351-10 Administration - Capital & Proj Vehicles	-	30,850.00	30,850.00	2021 Dodge Durango for Assistant City Administrator
---	---	-----------	-----------	---

Total Expenditure Change

30,850.00

(30,850.00)

Net Increase (Decrease) In Projected Fund Balance

City of Sedalia
DEPARTMENTAL MEMORANDUM

To : City Administrator Kelvin Shaw

From : Assistant City Administrator Matthew Wirt_____

Date : December 7, 2023

Ref : Car Purchase

City administration has located a 2021 Dodge Durango from the Kansas Highway Patrol (KSHP) for a total purchase price of \$30,850. The vehicle will be used by the assistant city administrator as governed in the respective contract. The purchase of the vehicle through KSHP meets City purchasing policy under the Cooperative Procurement Program as this is a form of State Surplus and "similar programs that meet the spirit and intent of these procedures in their process." The total price of the vehicle was not budgeted in FY23 administration fund. I request a budget amendment to purchase the vehicle from KSHP in the amount of \$30,850 in account 10-55-351-10.

Kansas Highway Patrol

Fleet Sales

930 NE Strait Ave.
Topeka, KS 66616
(785) 296-8535



KANSAS HIGHWAY PATROL

Agency	Sedalia Police Department	Invoice #:	Temporary
Address	300 W 3rd Street	Date:	12/6/2023
City	Sedalia	State	MO
	Zip		65301
		PO#:	
		Check #:	
Phone	660-826-0214	Email	mwirt@sedaliapolice.com
	Attn:	Chief Matthew Wirt	

Model Year	Description	Unit #	Qty	Unit Price	Total
2021	Dodge Durango Pursuit AWD 5.7 8 spd AT Remote start, Uconnect 4 Bluetooth, heated power mirrors & automatic temp control	21-368	1	\$29,850.00	\$29,850.00
	*Used Interior Lights		1	\$600.00	\$600.00
	*Used Siren System		1	\$400.00	\$400.00
	Color: Billet VIN: 1C4SDJFT1MC823495 Mileage: 49126				
				Page Total	\$30,850.00

Invoice Total **\$30,850.00**

Purchasers Signature _____

Date _____

Please Make Checks Payable To: Kansas Highway Patrol Car Fund
All Vehicles Must Be Picked Up In Topeka
Please pay from this invoice. No statement will be mailed

BILL NO. _____

ORDINANCE NO. _____

AN ORDINANCE AUTHORIZING AN AGREEMENT FOR TRANSPORT AND PURCHASE OF ROCK SALT.

WHEREAS, the City of Sedalia, Missouri, has received a bid from Hutchinson Salt Company, Inc. for delivery of rock salt meeting specific standards for the City's Public Works Department; and

WHEREAS, under the bid, the City of Sedalia, Missouri, shall give the sum and amount as specified, for delivery of said rock salt at the City's Public Works facility located at 901 E. Third Street as described in the proposed agreement attached hereto and incorporated by reference as though the proposed agreement were set forth herein. Said agreement contemplates four (4) one (1) year extensions.

NOW THEREFORE, BE IT ORDAINED BY THE COUNCIL OF THE CITY OF SEDALIA, MISSOURI, as follows:

Section 1. The Council of the City of Sedalia, Missouri, hereby approves and accepts the agreement by and between the City of Sedalia, Missouri, and Hutchinson Salt Company, Inc. attached hereto and incorporated by reference as though the proposed agreement were set forth herein in substantially the same form and content as proposed.

Section 2. The City Administrator is authorized and directed to execute and the City Clerk is hereby authorized and directed to attest and fix the seal of the City of Sedalia, Missouri, on the document as it has been proposed.

Section 3. The City Clerk is hereby directed to file in his office a duplicate or copy of the document after it has been executed by the parties or their duly authorized representatives.

Section 4. This ordinance shall take effect and be in full force and effect from and after its passage and approval.

Read two times by title, copies of the proposed ordinance having been made available for public inspection prior the time the bill is under consideration by the Council and passed by the Council of the City of Sedalia, Missouri this 18th day of December, 2023. .

Presiding Officer of the Council

Approved by the Mayor of said City this 18th day of December, 2023.

Andrew L. Dawson, Mayor

ATTEST:

Jason S. Myers
City Clerk

**CONTRACT AGREEMENT
BY AND BETWEEN
THE CITY OF SEDALIA, MISSOURI AND
HUTCHINSON SALT COMPANY
FOR SERVICE AND COMMODITIES: Transport and Purchase of Rock Salt**

This agreement made and entered into this 18th day of December, 2023, by and between the City of Sedalia, Missouri, hereinafter referred to as the “City” and Hutchinson Salt Company hereinafter referred to as the “Contractor” whose principal place of business is located at 136 West 12th Street, Baxter Springs, KS 66713.

This agreement between the City and the Contractor shall consist of (1) the Invitation for Bids (Exhibit A), and any amendments thereto, (2) the bid, as accepted, submitted in response to the Invitation for Bids (Exhibit B), and (3) the purchase order. In the event of a conflict in language between the documents referenced above, the Invitation for Bids and amendments thereto shall govern over the Contractor’s Bid and amendments thereto. However, the City reserves the right to clarify any Contractual relationship in writing with the concurrence of the Contractor, and such written clarification shall govern in the case of conflict with the applicable requirements stated in the Invitation for Bids or the Contractor’s Bid. In all other matters not affected by the written clarification, if any, the Invitation for Bids shall govern.

Any modification and supplementation of the Contract shall be upon written agreement of the duly authorized representatives of the contracting parties. No provision in the Contract shall be changed or modified without the execution of a formal amendment to the Contract, mutually agreed to by the City and the Contractor. This agreement is for one year, beginning on the date of the award. The City may, at its option, extend this agreement for up to four (4) additional one year terms.

Kelvin L. Shaw, City Administrator
City of Sedalia

Authorized Representative
Hutchinson Salt Company

ATTEST:

Jason S. Myers
City Clerk

**CITY OF SEDALIA
IFB #2024-010**

**BID FORM – PROPOSAL
ROCK SALT**

SUBMITTED BY Hutchinson Salt Company
(Company Name)

Pursuant to and in accordance with the above stated Invitation for Bid, the above signed hereby declares that they have examined the IFB documents and specifications for the item(s) listed below.

The undersigned proposes and agrees, if their Bid is accepted to furnish the item(s) submitted below as indicated below including delivery schedule, as detailed, and according to the prices products/services information submitted in the bidder response.

ITEM	QTY	DESCRIPTION	UNIT PRICE	EXTENDED AMOUNT
1.	2,000 tons	Rock Salt per specifications stated above. (medium size or approximately 1/4" in size). Delivery: <u>3-5</u> days after receipt of purchase order.	\$ <u>75.42</u> Per ton delivered	\$ <u>150,840</u>

ITEM	QTY	DESCRIPTION	UNIT PRICE	EXTENDED AMOUNT
2.	2,000 tons	Rock Salt per specifications stated above. (medium size or approximately 1/4" in size). No Delivery: Cost for Rock Salt Only (Picked up at contractor's facility by City of Sedalia Supplied Trucks.) Available for pick-up: <u>1</u> days after receipt of purchase order.	\$ <u>41.13</u> Per ton Customer Transported	\$ <u>82,260</u>

NOTE: Estimated Quantity: The quantities indicated in this bid document are estimates that pertain to the **total aggregate quantities** that may be ordered incrementally at multiple times throughout the contract period and each extension. The City of Sedalia makes no guarantees about single order quantities or total aggregate order quantities.

DELIVERY: F.O.B. DESTINATION

ACCEPT CITY'S CREDIT CARD: YES _____ NO

Prompt Payment Discount N/A % N/A Days, Net 30 Days

CITY OF SEDALIA
IFB #2024-010
ROCK SALT
AFFIDAVIT OF COMPLIANCE

To be submitted with vendor's Bid

We DO NOT take exception to the IFB Documents/Requirements.

We TAKE exception to the IFB Documents/Requirements as follows:

Specific exceptions are as follows: _____

I have carefully examined the Invitation for Bid and agree to abide by all submitted pricing, delivery, terms and conditions of this Bid unless otherwise stipulated herein.

Company Name Hutchinson Salt Co.

By Andy Bingham
(Authorized Person's Signature)

Andy Bingham, Vice President
(Print or type name and title of signer)

Company Address 136 West 12th
Baxter Springs, KS. 66713

Telephone Number 620-856-3332 x4

Fax Number: 620-856-3663

Date: 11-13-23

ADDENDA

Bidder acknowledges receipt of the following addendum:

Addendum No. 2024-010

Addendum No. _____

Addendum No. _____

Addendum No. _____

Addendum No. _____

Email andy.bingham@hutchsalt.com

Federal Tax ID No. 48-1085719

Document A310™ – 2010

Conforms with The American Institute of Architects AIA Document 310

Bid Bond

CONTRACTOR:

(Name, legal status and address)

Central Salt LLC
1420 State Hwy. 14
Lyons, KS 67554

SURETY:

(Name, legal status and principal place of business)

Liberty Mutual Insurance Company
175 Berkeley Street
Boston, MA 02116

This document has important legal consequences. Consultation with an attorney is encouraged with respect to its completion or modification.

Any singular reference to Contractor, Surety, Owner or other party shall be considered plural where applicable.

OWNER:

(Name, legal status and address)

City of Sedalia
200 S. Osage Avenue
Sedalia, MO 65301

BOND AMOUNT: \$ 5%

Five Percent of Amount Bid (Not to Exceed \$20,000)

(Not to Exceed \$20,000)

PROJECT:

(Name, location or address, and Project number, if any)

City of Sedalia, Missouri Public Works Department Street Invitation for Bid #2024-010 – Rock Salt

The Contractor and Surety are bound to the Owner in the amount set forth above, for the payment of which the Contractor and Surety bind themselves, their heirs, executors, administrators, successors and assigns, jointly and severally, as provided herein. The conditions of this Bond are such that if the Owner accepts the bid of the Contractor within the time specified in the bid documents, or within such time period as may be agreed to by the Owner and Contractor, and the Contractor either (1) enters into a contract with the Owner in accordance with the terms of such bid, and gives such bond or bonds as may be specified in the bidding or Contract Documents, with a surety admitted in the jurisdiction of the Project and otherwise acceptable to the Owner, for the faithful performance of such Contract and for the prompt payment of labor and material furnished in the prosecution thereof, or (2) pays to the Owner the difference, not to exceed the amount of this Bond, between the amount specified in said bid and such larger amount for which the Owner may in good faith contract with another party to perform the work covered by said bid, then this obligation shall be null and void, otherwise to remain in full force and effect. The Surety hereby waives any notice of an agreement between the Owner and Contractor to extend the time in which the Owner may accept the bid. Waiver of notice by the Surety shall not apply to any extension exceeding sixty (60) days in the aggregate beyond the time for acceptance of bids specified in the bid documents, and the Owner and Contractor shall obtain the Surety's consent for an extension beyond sixty (60) days.

If this Bond is issued in connection with a subcontractor's bid to a Contractor, the term Contractor in this Bond shall be deemed to be Subcontractor and the term Owner shall be deemed to be Contractor.

When this Bond has been furnished to comply with a statutory or other legal requirement in the location of the Project, any provision in this Bond conflicting with said statutory or legal requirement shall be deemed deleted herefrom and provisions conforming to such statutory or other legal requirement shall be deemed incorporated herein. When so furnished, the intent is that this Bond shall be construed as a statutory bond and not as a common law bond.

Signed and sealed this 15th day of November, 2023

Bryanna A. Bryan
(Witness)

Central Salt LLC

(Principal)

(Seal)

By: Lou Young

(Title)

Jamala Dour
(Witness)

Liberty Mutual Insurance Company

(Surety)

(Seal)

By: Nancy Singleton

(Title) Nancy Singleton

Attorney-in-Fact

Surety Phone No. 617-357-9500



Rock Salt
 IFB #2024 - 010
 November 15, 2023 2:00 p.m.
 Mayor's Conference Room

	Central Salt Attn: Lori Young 1420 State Road 14 Lyons, KS 67554 (620) 257-5626 ext 7821		Independent Salt Company Attn: Chris Tully 1126 20th Road, P.O. Box 36 Kanopolis, KS 67454 785-472-4421	
Quantity	2000 Tons	Extended Price	2000 Tons	Extended Price
Delivered Amount	\$81.84/Ton	\$163,680.00	\$77.96/Ton	\$155,920.00
Pick Up Amount	\$55.00/Ton	\$110,000000	No Bid	\$0.00
Notes:	No Delivery: Cost for Salt Only (Picked up at contractor's facility by City of Sedalia Supplied Trucks)	Error Cost Item 2 Listed as \$110,000000	No Delivery: Cost for Salt Only (Picked up at contractor's facility by City of Sedalia Supplied Trucks)	
Delivery Time	2-4 days after receipt of order		10-14 days after receipt of order	
Pick up Time	1 day after receipt of order		N/A	

	Kansas Salt, LLC Attn: Ryan Bauer PO Box 333 Louisburg, KS 66053 913-730-7258		Hutchinson Salt Company, Inc Attn: Andy Bingham 136 West 12th Street Baxter Springs, KS 66713 620-856-3332, Ext 4	
Quantity	2000 Tons	Extended Price	2000 Tons	Extended Price
Delivered Amount	\$77.95/Ton	\$155,900.00	\$75.42/Ton	\$150,840.00
Pick Up Amount	\$46.00/Ton	\$92,000.00	41.13/Ton	\$82,260.00
Notes:	No Delivery: Cost for Salt Only (Picked up at contractor's facility by City of Sedalia Supplied Trucks)		No Delivery: Cost for Salt Only (Picked up at contractor's facility by City of Sedalia Supplied Trucks)	
Delivery Time	2-4 days after receipt of order		3-5 days after receipt of order	
Pick up Time	2 days after receipt of order		1 day after receipt of order	

Cargill 24950 Country Club Blvd., Suite 450 North Olmsted, OH 44070 - No Bid

Compass Minerals 9900 West 109th Street, Suite 100, Overland Park, KS 66210 - No Bid



Let's Cross Paths

City of Sedalia

200 S. Osage

Sedalia, MO 65301

(660) 827-3000 www.sedalia.com

To: Kelvin Shaw, City Administrator
Through: Chris Davies, Public Works Director 
From: Justin Bray, Operations Manager
Date: November 29, 2023
Subject: IFB# 2024 – 010 Rock Salt

On November 15, 2023, sealed bids were opened for procurement of rock salt and delivery. Four (4) bids were submitted by Central Salt, Lyons, KS, Independent Salt Company, Kanopolis, KS, Kansas Salt, LLC, Louisburg, KS, and Hutchinson Salt Company, Inc, Baxter Springs, KS for bulk delivery to the Public Works facility located at 901 E 3rd St. These bids ranged from &75.42 to \$81.84 per ton. Additionally Central Salt, Kansas Salt, LLC, and Hutchinson Salt Company, Inc provided amounts for pick up at the vendor's facility, if needed. Those amounts ranged from \$41.13 to \$55.00 per ton.

The Public Works Department is recommending approval to the low bidder, for both delivery (\$75.42) and pick up (\$41.13) if need be, Hutchinson Salt Company, Inc, 136 West 12th St., Baxter Springs, KS 66713. This is a new vendor the City has not previously worked with, but they received positive reviews from their references.

**CITY COUNCIL
OF THE CITY OF SEDALIA, MISSOURI**

RESOLUTION NO. _____

**A RESOLUTION OF THE CITY COUNCIL OF THE CITY OF SEDALIA, MISSOURI,
STATING FACTS AND REASONS FOR THE NECESSITY TO AMEND AND INCREASE
THE CITY'S ANNUAL BUDGET FOR FISCAL YEAR 2024.**

WHEREAS, Section 67.010 of the Revised Statutes of Missouri requires each political subdivision of the State of Missouri ("State") to prepare an annual budget and establishes the requirements for that budget; and

WHEREAS, the City of Sedalia, Missouri ("City"), is a city of the third classification created pursuant to Chapter 77, RSMo, and is a political subdivision of the State of Missouri; and

WHEREAS, the City Council of the City adopted and approved the City's annual budget for Fiscal Year 2023 in accordance with the requirements of Section 67.010, RSMo, by Ordinance No. 11535 on March 21, 2022, and

WHEREAS, Sections 67.030 and 67.040 authorize and provide a procedure for the City Council to amend the City's annual budget to increase expenditures in any fund; and

WHEREAS, expenses for City's operations for Fiscal Year 2024 have been higher than budgeted, but do not exceed revenues plus the City's unencumbered balance brought forward from previous years; and

WHEREAS, the City Council of the City desire to state the facts and reasons necessitating an amendment to increase certain expenditures in the Fiscal Year 2024 annual budget.

**NOW THEREFORE, BE IT RESOLVED BY THE CITY COUNCIL OF THE CITY
OF SEDALIA, MISSOURI, AS FOLLOWS:**

Section 1. Expenditures from the City's WPC Fund must be increased by a total of \$757,800 above the amount authorized in the adopted annual budget for Fiscal Year 2024. An amendment to increase said budget is necessary for the following facts and reasons:

- A. Purchase two side loader garbage trucks.

Section 2. This Resolution shall take effect immediately upon its execution by the Mayor or otherwise as provided by law.

PASSED by the City Council of the City of Sedalia, Missouri, on December 18, 2023

Presiding Officer of the Council

ATTEST: _____
Jason S. Myers, City Clerk

BILL NO. _____

ORDINANCE NO. _____

AN ORDINANCE AMENDING THE BUDGET FOR THE FISCAL YEAR 2023-2024 AND APPROVING AND ACCEPTING A QUOTE FOR THE PURCHASE OF TWO SIDE LOADER GARBAGE TRUCKS.

NOW THEREFORE, BE IT ORDAINED BY THE COUNCIL OF THE CITY OF SEDALIA, MISSOURI as follows:

Section 1. The 2023-2024 fiscal year budget beginning April 1, 2023 and ending March 31, 2024 is hereby amended to modify certain budgeted line items as they appear on the attached schedule and made a part hereof as Exhibit A as if fully set out herein.

Section 2. The City Council of Sedalia, Missouri hereby approves and accepts the quote by and between the City of Sedalia, Missouri and Elliott Equipment Company and shall pay the total sum and amount of Seven Hundred Fifty-Seven Thousand Eight Hundred Dollars (\$757,800.00), for the purchase of two 2024 Peterbilt 31 YD automated side loader garbage trucks as more fully described in the quote attached to this Ordinance and incorporated by reference herein.

Section 3. The Mayor or City Administrator are authorized and directed to execute and the City Clerk is hereby authorized and directed to attest and fix the seal of the City of Sedalia, Missouri on the quote in substantively the same form and content as the quote has been proposed.

Section 4. This ordinance shall be in full force and effect from and after its passage and approval.

Read two times by title, copies of the proposed ordinance having been made available for public inspection prior to the time the bill is under consideration by the Council and passed by the Council of the City of Sedalia, Missouri this 18th day of December 2023.

Presiding Officer of the Council

Approved by the Mayor of said City this 18th day of December 2023.

Andrew L. Dawson, Mayor

ATTEST:

Jason S. Myers, City Clerk

Exhibit A
City of Sedalia
FY24 Budget Amendment 12/18/2023 WPC Side Loader Garbage Trucks Purchase

Account / Description	Current Budget	Change	Amended Budget	Comments
Expenditures / Uses of Funds				
65-51-351-86 Refuse Truck	-	757,800.00	757,800.00	Side Loader Garbage Trucks (2)
Total Expenditure Change		<u>757,800.00</u>		
		<u>(757,800.00)</u>		Net Increase (Decrease) In Projected Fund Balance



Let's Cross Paths

City of Sedalia

200 S. Osage

Sedalia, MO 65301

(660) 827-3000 www.sedalia.com

MEMO

TO: Kelvin L. Shaw, City Administrator
Matthew Wirt, Assistant City Administrator
Jessica Pyle, Finance Director
Jason Myers, City Clerk

FROM: Christopher R. Davies, P.E., Public Works Director 

DATE: December 13, 2023

**RE: BUDGET AMENDMENT SANITATION – PURCHASE OF TWO (2) 2024
PETERBILT 31 YD AUTOMATED SIDE LOADER GARBAGE TRUCKS**

The Public Works Department, Sanitation, is requesting an increase of \$757,800.00 in Account No. 65-51-351-00 to purchase two (2) 2024 Peterbilt 520 New Way Sidewinder 31 YD Automated Side Loader.

The City provides residential garbage service to its residents. To provide the service the City should have six (6) vehicles: Four (4) side loaders and two (2) rear dumps. This would provide the City with one (1) back up for each type of vehicle. Approximately five (5) years ago, the city purchased the side loaders, which based on my opinion, were not adequate to perform the job. Based on the current year budget we are over budget by 100%, and we still have a little of 3 months to go. The major issue with the current trucks are that they are undersized for the job and the arm is not designed for picking up such large loads.

The vehicles we are asking permission to purchase have significant advantages; 1) they are tandem axel, which allows the truck to carry the heavy loads, 2) the arm has less moving parts, is able to reach out vertically further, can handle up to 1000lbs, 3) and is able to hold 31 YD's of trash.

Please let me know if you need additional information or have any questions. I can be reached at (660)-851-7635 between the hours of 8:00am and 5:00pm Monday thru Friday.

RECOMMENDATION: It is Public Works recommendation that City Council approve the requested budget increase of \$757,800.00. For the purchase of two (2) 2024 Peterbilt 520 New Way Sidewinder 31 YD Automated Side Loader.

NEW WAY SIDEWINDER XTR

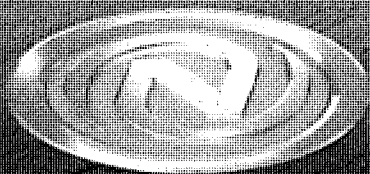

TRACTION IN ANY ENVIRONMENT

With the New Way[®] Sidewinder XTR[®] Automated Side Loader, efficiency is always at your side. Enjoy smooth one-operator convenience and a faster compaction rate than any other side loader on the market. Combine the strongest frame-mounted arm in the industry—boasting a 12-foot reach—with the convenience of automated loading and the ability to maneuver in tight spaces and you have an agile, ultra-tough, overbuilt loader.

Chris Davies

From: Andrew Dawson <ADawson@sedalia.com>
Sent: Tuesday, December 5, 2023 6:27 PM
To: Kelvin L. Shaw; Andrew Dawson
Cc: Chris Davies; Matthew Wirt
Subject: Re: Trucks
Attachments: image002.png; image003.jpg

Yes, please proceed.

- Hon. Mayor Andrew L. Dawson

(P) 660-620-6526
(M) 660-473-4016
(A) 602 W 7th St Sedalia, MO 65301

"Always do right. This will gratify some people and astonish the rest"
-Mark Twain

LEGAL NOTICE: Under Missouri's Sunshine Law, all e-mails sent by or to me on this city-owned e-mail account may be subject to public disclosure

From: Kelvin L. Shaw <kshaw@sedalia.com>
Sent: Tuesday, December 5, 2023 6:25:08 PM
To: Andrew Dawson <ADawson@sedalia.com>
Cc: Chris Davies <CDavies@sedalia.com>; Matthew Wirt <mwirt@sedaliapolice.com>
Subject: RE: Trucks

Mayor

Chris and I discussed the below today. We have trucks down again or in limp mode to the point we are going to be picking up garbage tomorrow with skid steers and dump trucks again. As we have discussed, we were planning on putting together a proposal for purchasing new trucks with the budget proposal. However, it is getting increasingly difficult to keep running long enough to get to the next fiscal year. Therefore, we would like to put together a proposal to take to the next Council meeting. The two trucks below are available now and Justin is going to contact them to see if they will hold them for us until the 19th so we can see if Council will approve moving forward with them now at the 18th meeting. Chris is going to put together the background and why we recommend these trucks (which are heavier than the past trucks). Further, he will talk about how we may be able to get by with just the two. I will lay out the financial plan, but my current thinking is to loan the money from the General Fund to the Sanitation Fund to purchase these outright rather than a lease option again. We are also working on the volume based billing and the revenue net increase we need to make the fund solvent. We had planned to present this as part of the budget but may need to give at least a preview of it for this question now.

Are you ok with us putting this on the agenda? Are you ok with the thought process or plan?

Thanks

*Kelvin L. Shaw, CPA
City Administrator*

City of Sedalia
Direct Dial (660) 851-7615
kshaw@sedalia.com



From: Chris Davies <CDavies@sedalia.com>
Sent: Tuesday, December 5, 2023 4:01 PM
To: Kelvin L. Shaw <kshaw@sedalia.com>
Subject: FW: Trucks

Kelvin,

Please see information from email below. While I know this is a large purchase, it is my recommendation that we at the very least purchase one of these trucks if possible we should purchase both. Willing to sit down with you and chat about.

Thanks,

Chris Davies, P.E.
Public Works Director

From: Justin Bray <JBray@sedalia.com>
Sent: Tuesday, December 5, 2023 3:43 PM
To: Chris Davies <CDavies@sedalia.com>
Subject: Fwd: Trucks

Chris see attached, they have two open for January.

Sent from my iPhone

Begin forwarded message:

From: Kevin Hilgendorf <kevinh@elliottequipco.com>
Date: December 5, 2023 at 3:38:16 PM CST
To: Justin Bray <JBray@sedalia.com>
Subject: Trucks

11868E 2024 PETERBILT 520 NEW WAY SIDEWINDER 31 YD AUTOMATED SIDE LOADER
2024 Peterbilt 520, Paccar PX-9 380 HP diesel, Allison 4500RDS automatic transmission, tandem axle chassis
with New Way Sidewinder 31 cu yd automated side loader, frame mounted arm with 1,000 lb capacity and 12' reach, hydraulic hopper cover, triple camera system with 7" monitor, work lights, strobe lights
VIN: 116389 WO: 165247-1-1
\$378,900.00 plus F.E.T. Available January 2024

11869E 2024 PETERBILT 520 NEW WAY SIDEWINDER 31 YD AUTOMATED SIDE LOADER

2024 Peterbilt 520, Paccar PX-9 380 HP diesel, Allison 4500RDS automatic transmission, tandem axle chassis

with New Way Sidewinder 31 cu yd automated side loader, frame mounted arm with 1,000 lb capacity and 12'

reach, hydraulic hopper cover, triple camera system with 7" monitor, work lights, strobe lights

VIN: 116390 WO: 165247-1-2

\$378,900.00 plus F.E.T. Available January 2024



Kevin Hilgendorf

VP Sales – Southern Territory

Elliott Equipment Company

14219 Norby Road

Grandview, Mo. 64030

(816)-761-4840 ex. 2401 – Office

(515)-669-4351 – Cell

KevinH@elliottequipco.com

www.elliottequipco.com

Chris Davies

From: Andrew Dawson <ADawson@sedalia.com>
Sent: Tuesday, December 5, 2023 6:27 PM
To: Kelvin L. Shaw; Andrew Dawson
Cc: Chris Davies; Matthew Wirt
Subject: Re: Trucks
Attachments: image002.png; image003.jpg

Yes, please proceed.

- Hon. Mayor Andrew L. Dawson

(P) 660-620-6526
(M) 660-473-4016
(A) 602 W 7th St Sedalia, MO 65301

"Always do right. This will gratify some people and astonish the rest"
-Mark Twain

LEGAL NOTICE: Under Missouri's Sunshine Law, all e-mails sent by or to me on this city-owned e-mail account may be subject to public disclosure

From: Kelvin L. Shaw <kshaw@sedalia.com>
Sent: Tuesday, December 5, 2023 6:25:08 PM
To: Andrew Dawson <ADawson@sedalia.com>
Cc: Chris Davies <CDavies@sedalia.com>; Matthew Wirt <mwirt@sedaliapolice.com>
Subject: RE: Trucks

Mayor

Chris and I discussed the below today. We have trucks down again or in limp mode to the point we are going to be picking up garbage tomorrow with skid steers and dump trucks again. As we have discussed, we were planning on putting together a proposal for purchasing new trucks with the budget proposal. However, it is getting increasingly difficult to keep running long enough to get to the next fiscal year. Therefore, we would like to put together a proposal to take to the next Council meeting. The two trucks below are available now and Justin is going to contact them to see if they will hold them for us until the 19th so we can see if Council will approve moving forward with them now at the 18th meeting. Chris is going to put together the background and why we recommend these trucks (which are heavier than the past trucks). Further, he will talk about how we may be able to get by with just the two. I will lay out the financial plan, but my current thinking is to loan the money from the General Fund to the Sanitation Fund to purchase these outright rather than a lease option again. We are also working on the volume based billing and the revenue net increase we need to make the fund solvent. We had planned to present this as part of the budget but may need to give at least a preview of it for this question now.

Are you ok with us putting this on the agenda? Are you ok with the thought process or plan?

Thanks

Kelvin L. Shaw, CPA
City Administrator

City of Sedalia
Direct Dial (660) 851-7615
kshaw@sedalia.com



From: Chris Davies <CDavies@sedalia.com>
Sent: Tuesday, December 5, 2023 4:01 PM
To: Kelvin L. Shaw <kshaw@sedalia.com>
Subject: FW: Trucks

Kelvin,

Please see information from email below. While I know this is a large purchase, it is my recommendation that we at the very least purchase one of these trucks if possible we should purchase both. Willing to sit down with you and chat about.

Thanks,

Chris Davies, P.E.
Public Works Director

From: Justin Bray <JBray@sedalia.com>
Sent: Tuesday, December 5, 2023 3:43 PM
To: Chris Davies <CDavies@sedalia.com>
Subject: Fwd: Trucks

Chris see attached, they have two open for January.

Sent from my iPhone

Begin forwarded message:

From: Kevin Hilgendorf <kevinh@elliottequipco.com>
Date: December 5, 2023 at 3:38:16 PM CST
To: Justin Bray <JBray@sedalia.com>
Subject: Trucks

11868E 2024 PETERBILT 520 NEW WAY SIDEWINDER 31 YD AUTOMATED SIDE LOADER
2024 Peterbilt 520, Paccar PX-9 380 HP diesel, Allison 4500RDS automatic transmission, tandem axle chassis
with New Way Sidewinder 31 cu yd automated side loader, frame mounted arm with 1,000 lb capacity and 12' reach, hydraulic hopper cover, triple camera system with 7" monitor, work lights, strobe lights
VIN: 116389 WO: 165247-1-1
\$378,900.00 plus F.E.T. Available January 2024

11869E 2024 PETERBILT 520 NEW WAY SIDEWINDER 31 YD AUTOMATED SIDE LOADER

2024 Peterbilt 520, Paccar PX-9 380 HP diesel, Allison 4500RDS automatic transmission, tandem axle chassis

with New Way Sidewinder 31 cu yd automated side loader, frame mounted arm with 1,000 lb capacity and 12'

reach, hydraulic hopper cover, triple camera system with 7" monitor, work lights, strobe lights

VIN: 116390 WO: 165247-1-2

\$378,900.00 plus F.E.T. Available January 2024



Kevin Hilgendorf

VP Sales – Southern Territory

Elliott Equipment Company

14219 Norby Road

Grandview, Mo. 64030

(816)-761-4840 ex. 2401 – Office

(515)-669-4351 – Cell

KevinH@elliottequipco.com

www.elliottequipco.com

**CITY COUNCIL
OF THE CITY OF SEDALIA, MISSOURI**

RESOLUTION NO. _____

**A RESOLUTION OF THE CITY COUNCIL OF THE CITY OF SEDALIA, MISSOURI,
STATING FACTS AND REASONS FOR THE NECESSITY TO AMEND AND INCREASE
THE CITY'S ANNUAL BUDGET FOR FISCAL YEAR 2024.**

WHEREAS, Section 67.010 of the Revised Statutes of Missouri requires each political subdivision of the State of Missouri ("State") to prepare an annual budget and establishes the requirements for that budget; and

WHEREAS, the City of Sedalia, Missouri ("City"), is a city of the third classification created pursuant to Chapter 77, RSMo, and is a political subdivision of the State of Missouri; and

WHEREAS, the City Council of the City adopted and approved the City's annual budget for Fiscal Year 2023 in accordance with the requirements of Section 67.010, RSMo, by Ordinance No. 11535 on March 21, 2022, and

WHEREAS, Sections 67.030 and 67.040 authorize and provide a procedure for the City Council to amend the City's annual budget to increase expenditures in any fund; and

WHEREAS, expenses for City's operations for Fiscal Year 2024 have been higher than budgeted, but do not exceed revenues plus the City's unencumbered balance brought forward from previous years; and

WHEREAS, the City Council of the City desire to state the facts and reasons necessitating an amendment to increase certain expenditures in the Fiscal Year 2024 annual budget.

NOW THEREFORE, BE IT RESOLVED BY THE CITY COUNCIL OF THE CITY OF SEDALIA, MISSOURI, AS FOLLOWS:

Section 1. Expenditures from the City's WPC Fund must be increased by a total of \$267,364.95 above the amount authorized in the adopted annual budget for Fiscal Year 2024. An amendment to increase said budget is necessary for the following facts and reasons:

- A. Purchase Rear Load Garbage Truck and Camera to replace truck loss as a result of vehicle accident.

Section 2. This Resolution shall take effect immediately upon its execution by the Mayor or otherwise as provided by law.

PASSED by the City Council of the City of Sedalia, Missouri, on December 18, 2023

Presiding Officer of the Council

ATTEST: _____
Jason S. Myers, City Clerk

BILL NO. _____

ORDINANCE NO. _____

AN ORDINANCE AMENDING THE BUDGET FOR THE FISCAL YEAR 2023-2024 AND RATIFYING THE PURCHASE OF A REAR LOAD GARBAGE TRUCK AND CAMERA.

NOW THEREFORE, BE IT ORDAINED BY THE COUNCIL OF THE CITY OF SEDALIA, MISSOURI as follows:

Section 1. The 2023-2024 fiscal year budget beginning April 1, 2023 and ending March 31, 2024 is hereby amended to modify certain budgeted line items as they appear on the attached schedule and made a part hereof as Exhibit A as if fully set out herein.

Section 2. The City Council of Sedalia, Missouri hereby ratifies the purchase of a rear load garbage truck and camera system from Elliott Equipment Company in the total sum and amount of Two Hundred Sixty-Seven Thousand Three Hundred Sixty-Four Dollars and Ninety-Five Cents (\$267,364.95), offset by a reimbursement of insurance proceeds in the amount of \$207,364.95 as more fully described in the documents attached to this Ordinance and incorporated by reference herein.

Section 3. The Mayor or City Administrator are authorized and directed to execute and the City Clerk is hereby authorized and directed to attest and fix the seal of the City of Sedalia, Missouri on the documents attached in substantively the same form and content as they have been proposed.

Section 4. This ordinance shall be in full force and effect from and after its passage and approval.

Read two times by title, copies of the proposed ordinance having been made available for public inspection prior to the time the bill is under consideration by the Council and passed by the Council of the City of Sedalia, Missouri this 18th day of December 2023.

Presiding Officer of the Council

Approved by the Mayor of said City this 18th day of December 2023.

Andrew L. Dawson, Mayor

ATTEST:

Jason S. Myers, City Clerk

Exhibit A
City of Sedalia
FY24 Budget Amendment 12/18/2023 WPC Rear Load Garbage Truck Purchase

Account / Description	Current Budget	Change	Amended Budget	Comments
Revenues / Source of Funds				
65-00-510-00 Insurance Proceeds	-	(207,364.95)	(207,364.95)	Insurance Proceeds from Loss
	-		-	
Total Revenue Change		<u>(207,364.95)</u>		
Expenditures / Uses of Funds				
65-51-351-86 Refuse Truck	-	265,000.00	265,000.00	Rear Load Garbage Truck
65-51-351-86 Refuse Truck	-	2,364.95	2,364.95	Camera for Truck
Total Expenditure Change		<u>267,364.95</u>		
		<u>(60,000.00)</u>		Net Increase (Decrease) In Projected Fund Balance



Let's Cross Paths

City of Sedalia

200 S. Osage

Sedalia, MO 65301

(660) 827-3000 www.sedalia.com

MEMO

TO: Kelvin L. Shaw, City Administrator
Matthew Wirt, Assistant City Administrator
Jessica Pyle, Finance Director
Jason Myers, City Clerk

FROM: Christopher R. Davies, P.E., Public Works Director 

DATE: December 12, 2023

RE: BUDGET AMENDMENT SANITATION – PURCHASE OF REAR LOAD TRASH TRUCK

The Public Works Department, Sanitation, is requesting an increase of \$60,000.00 in Account No. 65-51-351-00 to purchase one (1) rear load garbage truck; 2024 New Western Star 47X, with a 25 cubic yard New Way Cobra Magnum rear loader.

On September 29, 2023, a city vehicle (Number 518 (2022 International Rear Load Refuse Truck), while conducting City business was involved in an accident. After investigating the accident Moperm, declared the vehicle to be a total loss and issued a check to the City of Sedalia in the amount of \$207,364.95 (minus the \$1000.00) deductible. On November 21, 2023, Kelvin L. Shaw, City Administrator, sent a memo to Mayor Andrew Dawson requesting the emergency purchase of a new rear load garbage truck priced at \$256,000.00 from Elliott Equipment Co.; Mayor Dawson approved the Emergency purchase on the same day.

1. New Rear Load – Elliott Equip. Co.	\$265,000.00
2. Moperm Check	- \$207,364.95
NET:	\$ 57,635.05
3. ADDED – Camera System (estimated)	+ \$2,364.95
TOTAL:	\$ 60,000.00

Please let me know if you need additional information or have any questions. I can be reached at (660)-851-7635 between the hours of 8:00am and 5:00pm Monday thru Friday.

RECOMMENDATION: It is Public Works recommendation that City Council approve the requested budget increase of \$60,000.00.



3100 West 76th Street
Davenport, IA 52806
Ph: 563-391-4840

Elliott Sanitation Equip. Co.
1245 Dawes Avenue
Lincoln, NE 68521
Ph: 402-474-4840

4000 SE Beisser Drive
Grimes, IA 50111
Ph: 515-986-4840
Fx: 515-986-9530

14001 Botts Rd.
Grandview, MO 64030
Ph: 816-761-4840

4400 E 60th Ave
Commerce City, CO 80022
Ph: 303-853-4840

Quote

Date	Quote #
11/21/2023	19992
Proposed Shipping Date	
Approx. 2-3 weeks	
Terms	
Due on receipt	
Rep	
KMH	

City of Sedalia
200 S Osage
Sedalia, MO 65301

Here is our quotation on the goods named, subject to the conditions noted:

CONDITIONS: The prices and terms on this quotation are not subject to verbal changes or other agreements unless approved in writing by the Home Office of the Seller. Prices are based on costs and conditions existing on date of quotation and are subject to change by the Seller before final acceptance. All quotations and agreements are contingent upon strikes, accidents, fires, availability of materials and all other causes beyond our control. Typographical and stenographic errors subject to correction. Purchaser agrees to accept either overage or shortage not in excess of ten percent to be charged for pro-rata. Purchaser assumes liability for patent and copyright infringement when goods are made to Purchaser's specifications. When quotation specifies material to be furnished by the purchaser, ample allowance must be made for reasonable spoilage and material must be of suitable quality to facilitate efficient production. Quoted Prices are good for 60 days.

Conditions not specifically stated herein shall be governed by established trade customs. Terms inconsistent with those stated herein which may appear on Purchaser's formal order will not be binding on the Seller.

TERMS: Equipment is due on receipt. Carts, Containers, Parts & service are Net 30 unless otherwise noted on your account. Balances over 30 days from the date of invoice are subject to finance charges up to 1.5% per month.

Qty	Item	Description	Price	Total
1	11699E	2024 New Western Star 47X, Cummins L9 350 HP diesel, Allison 3000RDS automatic, tandem axle chassis with 25 cu yd New Way Cobra Magnum rear loader, reeving winch, kicker bar, (2) Bayne cart tippers, color camera system, work lights, strobe lights, 1 year body and hydraulic warranty, 2 year cylinder warranty. VIN: UR6634	265,000.00	265,000.00

Total \$265,000.00

TO CONFIRM ORDER, SIGN AND RETURN

X _____

Prepared for:
Rick VanWassenhove
ELLIOTT EQUIPMENT CO
3100 W 76th Ave
Davenport, IA 52806
Phone: 563-391-4840

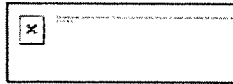

Prepared by:
Paul Moritz
TRANSWEST TRUCK TRAILER RV
20770 E. I-76 FRONTAGE ROAD
BRIGHTON, CO 80603
Phone: (303) 301-7409

S P E C I F I C A T I O N P R O P O S A L

Description
Price Level
WST 47X/49X PRL-27X (EFF:MY24 ORDERS)
Data Version
SPECPRO21 DATA RELEASE VER 016
Vehicle Configuration
WESTERN STAR 47X 2024 MODEL YEAR SPECIFIED SET BACK AXLE - TRUCK STRAIGHT TRUCK PROVISION, NON-TOWING LH PRIMARY STEERING LOCATION
General Service
TRUCK CONFIGURATION DOMICILED, USA (EXCLUDING CALIFORNIA AND CARB OPT-IN STATES) REFUSE SERVICE SANITATION BUSINESS SEGMENT MOIST BULK COMMODITY TERRAIN/DUTY: 100% (ALL) OF THE TIME, IN TRANSIT, IS SPENT ON PAVED ROADS MAXIMUM 8% EXPECTED GRADE SMOOTH CONCRETE OR ASPHALT PAVEMENT - MOST SEVERE IN-TRANSIT (BETWEEN SITES) ROAD SURFACE WESTERN STAR VOCATIONAL WARRANTY EXPECTED FRONT AXLE(S) LOAD : 18000.0 lbs EXPECTED REAR DRIVE AXLE(S) LOAD : 46000.0 lbs EXPECTED GROSS VEHICLE WEIGHT CAPACITY : 64000.0 lbs

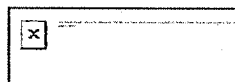

Prepared for:
Rick VanWassenhove
ELLIOTT EQUIPMENT CO
3100 W 76th Ave
Davenport, IA 52806
Phone: 563-391-4840



Prepared by:
Paul Moritz
TRANSWEST TRUCK TRAILER RV
20770 E. I-76 FRONTAGE ROAD
BRIGHTON, CO 80603
Phone: (303) 301-7409

	Description
Truck Service	REFUSE, SIDE LOAD OR REAR PACKER BODY - UNLOADS IN A LANDFILL ELLIOTT EQUIPMENT COMPANY
Engine	CUM L9 350 HP @ 2200 RPM, 2200 GOV RPM, 1050 LB-FT @ 1200 RPM, REFUSE
Electronic Parameters	74 MPH ROAD SPEED LIMIT CRUISE CONTROL SPEED LIMIT SAME AS ROAD SPEED LIMIT PTO MODE ENGINE RPM LIMIT - 1400 RPM PTO MODE THROTTLE OVERRIDE - LIMIT TO 1400 RPM PTO RPM WITH CRUISE SET SWITCH - 1400 RPM PTO RPM WITH CRUISE RESUME SWITCH - 900 RPM PTO GOVERNOR RAMP RATE - 1000 RPM PER SECOND ONE REMOTE PTO SPEED PTO SPEED 1 SETTING - 1100 RPM PTO MINIMUM RPM - 700 PTO 1, DASH SWITCH, ENGAGE BEFORE DRIVING
Engine Equipment	2010 EPA/CARB/GHG21 CONFIGURATION NO 2008 CARB EMISSION CERTIFICATION STANDARD OIL PAN ENGINE MOUNTED OIL CHECK AND FILL SIDE OF HOOD AIR INTAKE WITH ENGINE MOUNTED AIR CLEANER DR 12V 160 AMP 28-SI QUADRAMOUNT PAD ALTERNATOR WITH REMOTE BATTERY VOLT SENSE (3) DTNA, GENUINE, HIGH TEMP AGM STARTING AND CYCLING, MIN 2775CCA, 570RC, THREADED STUD BATTERIES PASSENGER SEAT BATTERY BOX VENTED TO OUTSIDE OF CAB BATTERY BOX MOUNTED UNDER PASSENGER SEAT



Prepared for:
Rick VanWassenhove
ELLIOTT EQUIPMENT CO
3100 W 76th Ave
Davenport, IA 52806
Phone: 563-391-4840



Prepared by:
Paul Moritz
TRANSWEST TRUCK TRAILER RV
20770 E. I-76 FRONTAGE ROAD
BRIGHTON, CO 80603
Phone: (303) 301-7409

Description

WIRE GROUND RETURN FOR BATTERY CABLES
WITH ADDITIONAL FRAME GROUND RETURN

PLASTIC BATTERY BOX COVER

POSITIVE LOAD DISCONNECT WITH CAB
MOUNTED CONTROL SWITCH MOUNTED
OUTBOARD DRIVER SEAT

POSITIVE AND NEGATIVE POSTS FOR
JUMPSTART LOCATED ON FRAME NEXT TO
STARTER

PROGRESSIVE LOW VOLTAGE DISCONNECT AT
12.3 VOLTS FOR DESIGNATED CIRCUITS

CUMMINS TURBOCHARGED 18.7 CFM AIR
COMPRESSOR WITH INTERNAL SAFETY VALVE

ELECTRONIC ENGINE INTEGRAL SHUTDOWN
PROTECTION SYSTEM

C-BRAKE BY JACOBS WITH LOW/OFF/HIGH
BRAKING DASH SWITCH

RH OUTBOARD UNDER STEP MOUNTED
HORIZONTAL AFTERTREATMENT SYSTEM
ASSEMBLY WITH RH B-PILLAR MOUNTED
VERTICAL TAILPIPE

ENGINE AFTERTREATMENT DEVICE,
AUTOMATIC OVER THE ROAD ACTIVE
REGENERATION AND VIRTUAL REGENERATION
REQUEST SWITCH IN CLUSTER AND DASH
MOUNTED INHIBIT SWITCH

11 FOOT 06 INCH (138 INCH+0/-5.9 INCH)
EXHAUST SYSTEM HEIGHT

STANDARD CURVE BRIGHT UPPER STACK(S)

RH CURVED VERTICAL TAILPIPE B-PILLAR
MOUNTED ROUTED FROM STEP

13 GALLON DIESEL EXHAUST FLUID TANK

UNPOLISHED ALUMINUM WST DIESEL
EXHAUST FLUID TANK COVER

LH HEAVY DUTY STANDARD DIESEL EXHAUST
FLUID TANK LOCATION

STANDARD DIESEL EXHAUST FLUID TANK CAP

PERFORATED SINGLE STAINLESS STEEL
MUFFLER/TAILOPIPE SHIELD WITH WESTERN
STAR LOGO

AIR POWERED ON/OFF ENGINE FAN CLUTCH

AUTOMATIC FAN CONTROL WITHOUT DASH
SWITCH, NON ENGINE MOUNTED

DETROIT FUEL/WATER SEPARATOR WITH
WATER IN FUEL SENSOR AND 12 VOLT
PREHEATER

CUMMINS SPIN ON FUEL FILTER



Prepared for:
Rick VanWassenhove
ELLIOTT EQUIPMENT CO
3100 W 76th Ave
Davenport, IA 52806
Phone: 563-391-4840



Prepared by:
Paul Moritz
TRANSWEST TRUCK TRAILER RV
20770 E. I-76 FRONTAGE ROAD
BRIGHTON, CO 80603
Phone: (303) 301-7409

Description

FULL FLOW OIL FILTER
1400 SQUARE INCH VOCATIONAL RADIATOR
ANTIFREEZE TO -34F, ETHYLENE GLYCOL PRE-
CHARGED SCA HEAVY DUTY COOLANT
GATES BLUE STRIPE COOLANT HOSES OR
EQUIVALENT
STANDARD CHARGE AIR COOLER PLUMBING
RADIATOR DRAIN VALVE
LOWER RADIATOR GUARD
PHILLIPS-TEMRO 1000 WATT/115 VOLT BLOCK
HEATER
CHROME ENGINE HEATER RECEPTACLE
MOUNTED UNDER LH DOOR
ELECTRIC GRID AIR INTAKE WARMER
DELCO 12V 39MT HD STARTER WITH
INTEGRATED MAGNETIC SWITCH

Transmission

N ALLISON 3000 RDS AUTOMATIC TRANSMISSION
WITH PTO PROVISION

Transmission Equipment

ALLISON VOCATIONAL PACKAGE 170 -
AVAILABLE ON 3000/4000 PRODUCT FAMILIES
WITH VOCATIONAL MODEL RDS AND EVS
ALLISON VOCATIONAL RATING FOR REFUSE
APPLICATIONS AVAILABLE WITH ALL PRODUCT
FAMILIES
PRIMARY MODE GEARS, LOWEST GEAR 1,
START GEAR 1, HIGHEST GEAR 6, AVAILABLE
FOR 3000/4000 PRODUCT FAMILIES ONLY
SECONDARY MODE GEARS, LOWEST GEAR 1,
START GEAR 1, HIGHEST GEAR 6, AVAILABLE
FOR 3000/4000 PRODUCT FAMILIES ONLY
S5 PERFORMANCE LIMITING PRIMARY SHIFT
SCHEDULE, AVAILABLE FOR 3000/4000
PRODUCT FAMILIES ONLY
S5 PERFORMANCE LIMITING SECONDARY
SHIFT SCHEDULE, AVAILABLE FOR 3000/4000
PRODUCT FAMILIES ONLY
2200 RPM PRIMARY MODE SHIFT SPEED
2200 RPM SECONDARY MODE SHIFT SPEED
FUEL SENSE 2.0 DISABLED - PERFORMANCE -
TABLE BASED
MAXIMUM ENGINE SPEED FOR PTO
OPERATION 1600 RPM



Prepared for:
Rick VanWassenhove
ELLIOTT EQUIPMENT CO
3100 W 76th Ave
Davenport, IA 52806
Phone: 563-391-4840



Prepared by:
Paul Moritz
TRANSWEST TRUCK TRAILER RV
20770 E. I-76 FRONTAGE ROAD
BRIGHTON, CO 80603
Phone: (303) 301-7409

Description

QUICKFIT BODY LIGHTING CONNECTOR UNDER CAB, WITH BLUNTCUTS
ELECTRONIC TRANSMISSION WIRING TO CUSTOMER INTERFACE CONNECTOR
CHELSEA PTO - CHL280GMFJP B5RK
PTO MOUNTING, RH SIDE OF MAIN TRANSMISSION ALLISON & EATON FULLER
MAGNETIC PLUGS, ENGINE DRAIN, TRANSMISSION DRAIN, AXLE(S) FILL AND DRAIN
HEAVY DUTY ELECTRONIC TRANSMISSION SHIFT CONTROL, COLUMN MOUNTED
WATER TO OIL TRANSMISSION COOLER
TRANSMISSION OIL CHECK AND FILL WITH ELECTRONIC OIL LEVEL CHECK
SYNTHETIC TRANSMISSION FLUID (TES-295 COMPLIANT)

Front Axle and Equipment

DETROIT DA-F-18.0-5 18,000# FL1 71.0 KPI/3.74
DROP SINGLE FRONT AXLE
CONMET PRESET PLUS PREMIUM IRON FRONT HUBS
MERITOR 16.5X6 Q+ CAST SPIDER CAM FRONT BRAKES, DOUBLE ANCHOR, FABRICATED SHOES
NON-ASBESTOS FRONT BRAKE LINING
CONMET CAST IRON FRONT BRAKE DRUMS
FRONT BRAKE DUST SHIELDS
FRONT OIL SEALS
VENTED FRONT HUB CAPS WITH WINDOW, CENTER AND SIDE PLUGS - OIL
HALDEX AUTOMATIC FRONT SLACK ADJUSTERS
DUAL POWER STEERING GEARS, BENDIX 16-20K
4 QUART POWER STEERING RESERVOIR
OIL/AIR POWER STEERING COOLER
CURRENT AVAILABLE SYNTHETIC 75W-90 FRONT AXLE LUBE

Front Suspension

20,000# TAPERLEAF FRONT SUSPENSION
MAINTENANCE FREE RUBBER BUSHINGS - FRONT SUSPENSION
FRONT SHOCK ABSORBERS



Prepared for:
Rick VanWassenhove
ELLIOTT EQUIPMENT CO
3100 W 76th Ave
Davenport, IA 52806
Phone: 563-391-4840



Prepared by:
Paul Moritz
TRANSWEST TRUCK TRAILER RV
20770 E. I-76 FRONTAGE ROAD
BRIGHTON, CO 80603
Phone: (303) 301-7409

Description

Rear Axle and Equipment

RT-46-160P 46,000# R-SERIES TANDEM REAR AXLE
CONMET PRESET PLUS PREMIUM IRON REAR HUBS
5.63 REAR AXLE RATIO
IRON REAR AXLE CARRIER WITH STANDARD AXLE HOUSING
MXL 17T MERITOR EXTENDED LUBE MAIN DRIVELINE WITH HALF ROUND YOKES
MXL 17T MERITOR EXTENDED LUBE INTERAXLE DRIVELINE WITH HALF ROUND YOKES
DRIVER CONTROLLED TRACTION DIFFERENTIAL - BOTH TANDEM REAR AXLES
(1) INTERAXLE LOCK VALVE, (1) DRIVER CONTROLLED DIFFERENTIAL LOCK FORWARD-REAR AND REAR-REAR AXLE VALVE
INDICATOR LIGHT FOR EACH INTERAXLE LOCKOUT SWITCH
INDICATOR LIGHT FOR EACH DIFFERENTIAL LOCKOUT SWITCH
MERITOR 16.5X7 Q+ CAST SPIDER CAM REAR BRAKES, DOUBLE ANCHOR, FABRICATED SHOES
NON-ASBESTOS REAR BRAKE LINING
BRAKE CAMS AND CHAMBERS ON FORWARD SIDE OF DRIVE AXLE(S)
CONMET CAST IRON REAR BRAKE DRUMS
REAR BRAKE DUST SHIELDS
REAR OIL SEALS
BENDIX EVERSURE LONGSTROKE 2-DRIVE AXLES SPRING PARKING CHAMBERS
HALDEX AUTOMATIC REAR SLACK ADJUSTERS WITH STAINLESS STEEL CLEVIS PINS
CURRENT AVAILABLE SYNTHETIC 75W-90 REAR AXLE LUBE
STANDARD REAR AXLE BREATHER(S)

Rear Suspension

TUFTRAC GEN2 46,000# REAR SPRING SUSPENSION
9.5 INCH NOMINAL RIDE HEIGHT (460MM GLOBAL REFERENCE HEIGHT)
AXLE CLAMPING GROUP
55 INCH AXLE SPACING

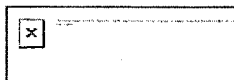

Prepared for:
Rick VanWassenhove
ELLIOTT EQUIPMENT CO
3100 W 76th Ave
Davenport, IA 52806
Phone: 563-391-4840



Prepared by:
Paul Moritz
TRANSWEST TRUCK TRAILER RV
20770 E. I-76 FRONTAGE ROAD
BRIGHTON, CO 80603
Phone: (303) 301-7409

	Description
Brake System	FORE/AFT AND TRANSVERSE CONTROL RODS
	REAR SHOCK ABSORBERS - TWO AXLES (TANDEM)
	WABCO 6S/4M ABS WITH TRACTION CONTROL WITH ATC SHUT OFF SWITCH
	REINFORCED NYLON, FABRIC BRAID AND WIRE BRAID CHASSIS AIR LINES
	RELAY VALVE WITH 5-8 PSI CRACK PRESSURE, NO REAR PROPORTIONING VALVE
Wheelbase & Frame	WABCO SYSTEM SAVER 1200 HEATED AIR DRYER WITH PRESSURE CONTROL VALVE
	AIR DRYER MOUNTED UNDER HOOD
	STEEL AIR BRAKE RESERVOIRS
	PULL CABLES ON ALL AIR RESERVOIR(S)
	5725MM (225 INCH) WHEELBASE
	9.5MM X 89.0MM X 304.0MM STEEL FRAME (0.37X3.50X11.97 INCH) 120 KSI
	2450MM (96 INCH) REAR FRAME OVERHANG
	FRAME OVERHANG RANGE: 91 INCH TO 100 INCH
	CALC'D BACK OF CAB TO REAR SUSP C/L (CA) : 160.24 in
	CALC'D FRAME LENGTH - OVERALL : 367.05 in
	FRAME HEIGHT TOP FRONT UNLADEN : 44.23 in
	FRAME HEIGHT TOP FRONT LADEN : 40.43 in
FRAME HEIGHT TOP REAR UNLADEN : 43.3 in	
FRAME HEIGHT TOP REAR LADEN : 40.95 in	
SQUARE END OF FRAME	
STANDARD WEIGHT ENGINE CROSSMEMBER	
STANDARD CAST ALUMINUM CROSSMEMBER BACK OF TRANSMISSION	
STANDARD CAST ALUMINUM MIDSHIP	
HEAVY DUTY REAR C-CHANNEL CROSSMEMBER, NON-TOWING	
STANDARD SUSPENSION CROSSMEMBER	
CAST ALUMINUM REAR SUSPENSION CROSSMEMBER	
Chassis Equipment	UNPOLISHED ALUMINUM WST EQUIPMENT COVERS

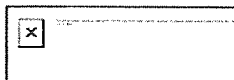

Prepared for:
Rick VanWassenhove
ELLIOTT EQUIPMENT CO
3100 W 76th Ave
Davenport, IA 52806
Phone: 563-391-4840



Prepared by:
Paul Moritz
TRANSWEST TRUCK TRAILER RV
20770 E. I-76 FRONTAGE ROAD
BRIGHTON, CO 80603
Phone: (303) 301-7409

	Description
	BRIGHT STEEL 1/8 INCH VOCATIONAL BUMPER REMOVABLE FRONT TOW/RECOVERY DEVICE, STORED ON CHASSIS FRAME BUMPER MOUNTING FOR SINGLE LICENSE PLATE BETTS B-25 PAINTED MUDFLAP BRACKETS WESTERN STAR LOGO BLACK MUDFLAPS CLASS 10.9 THREADED METRIC FASTENERS EXTERIOR HARNESSES WRAPPED IN ABRASION TAPE
Fuel Tanks	100 GALLON/378 LITER ALUMINUM FUEL TANK - LH 25 INCH DIAMETER FUEL TANK(S) PLAIN ALUMINUM/PAINTED STEEL FUEL/HYDRAULIC TANK(S) WITH PAINTED BANDS FUEL TANK(S) FORWARD 10 GALLONS ADDITIONAL FUEL PLAIN STEP FINISH FUEL TANK CAP(S) EQUIFLO INBOARD FUEL SYSTEM HIGH TEMPERATURE REINFORCED NYLON FUEL LINE
Tires	MICHELIN XZY-3 385/65R22.5 18 PLY RADIAL FRONT TIRES MICHELIN X WORKS D 11R22.5 16 PLY RADIAL REAR TIRES
Wheels	ALCOA LVL ONE 82462X 22.5X12.25 10-HUB PILOT 4.68 INSET 10-HAND ALUMINUM DISC FRONT WHEELS ALCOA LVL ONE 88267X ALUMINUM OUTSIDE, ACCURIDE 51637 STEEL INSIDE; 22.5X8.25 10- HUB PILOT DISC REAR WHEELS FRONT WHEEL MOUNTING NUTS REAR WHEEL MOUNTING NUTS
Cab Exterior	111.6 INCH BBC CONVENTIONAL ALUMINUM CAB STAINLESS STEEL CAB ACCENT MOLDING



Prepared for:
Rick VanWassenhove
ELLIOTT EQUIPMENT CO
3100 W 76th Ave
Davenport, IA 52806
Phone: 563-391-4840



Prepared by:
Paul Moritz
TRANSWEST TRUCK TRAILER RV
20770 E. I-76 FRONTAGE ROAD
BRIGHTON, CO 80603
Phone: (303) 301-7409

Description

FRONT FENDERS
BOLT-ON MOLDED FLEXIBLE FENDER
EXTENSIONS
INTERIOR GRAB HANDLES WITH ADDED
LOWER LH AND RH A PILLAR GRAB HANDLES
AND LH AND RH EXTERIOR NON-SLIP GRAB
HANDLES
BRIGHT HOOD MOUNTED AIR INTAKE GRILLE,
BLACK SCREEN, WITH LED ACCENT LIGHTS
X-SERIES STEEL REINFORCED ALUMINUM CAB
X-SERIES VOCATIONAL HOOD
HOOD OPENING ASSIST WITH LOCKING STRUT
WESTERN STAR NAMEPLATES
DUAL HADLEY SD-978 26 INCH RECTANGULAR
AIR HORNS
DUAL ELECTRIC HORNS
REAR LICENSE PLATE MOUNT END OF FRAME
DUAL STAGE INTELLIGENT LED HEADLIGHTS
WITH HEATED LENS SYSTEM
ROOF MOUNTED LED MARKER LIGHTS
DAYTIME RUNNING LIGHTS
INTEGRAL LED STOP/TAIL/BACKUP LIGHTS
WITH 7 EXTRA FEET OF WIRE MOUNTED END
OF FRAME
LED REAR FACING TURN SIGNAL LAMPS IN
CONVEX MIRROR LENS IN ADDITION TO
STANDARD
C-BAR MIRROR SYSTEM WITH DUAL HEATED
MIRRORS WITH INTEGRAL HEATED CONVEX,
DUAL REMOTE, TURN SIGNAL, STAINLESS
STEEL BACK COVER, AND BRIGHT C-BAR
102 INCH EQUIPMENT WIDTH
LH AND RH CONVEX MIRRORS INTEGRAL WITH
PRIMARY MIRRORS
RH DOWN VIEW MIRROR
STANDARD SIDE/REAR REFLECTORS
UNPOLISHED ALUMINUM WST
AFTERTREATMENT SYSTEM COVER
HIGH VISIBILITY 3-PIECE SOLAR TINTED REAR
WINDOW, (1) 31 INCH X 20 INCH SOLAR TINTED
REAR WINDOW, (2) 9 INCH X 20 INCH
1-PIECE ROPED-IN SOLAR GREEN GLASS
WINDSHIELD
8 LITER (2 GAL) WINDSHIELD WASHER
RESERVOIR, CAB MOUNTED, WITH FLUID
LEVEL INDICATOR



Prepared for:
Rick VanWassenhove
ELLIOTT EQUIPMENT CO
3100 W 76th Ave
Davenport, IA 52806
Phone: 563-391-4840



Prepared by:
Paul Moritz
TRANSWEST TRUCK TRAILER RV
20770 E. I-76 FRONTAGE ROAD
BRIGHTON, CO 80603
Phone: (303) 301-7409

	Description
Cab Interior	WHITE WINTERFRONT X-SERIES BASE INTERIOR TRIM LEVEL PACKAGE QUARRY GRAY VINYL BASE LEVEL INTERIOR CARBON WITH BASE BLACK ACCENT BLACK MATS (1) DASH MOUNTED POWER OUTLETS AND (1) USB CHARGING OUTPUT FORWARD ROOF MOUNTED CONSOLE LH AND RH DOOR STORAGE POCKETS INTEGRATED INTO MOLDED DOOR PANELS (2) COAT HOOKS ON BACKWALL OF CAB DIGITAL ALARM CLOCK IN DRIVER DISPLAY THERMOS HOLDER INBOARD OF DRIVER SEAT 2-1/2 LB. FIRE EXTINGUISHER MOUNTED INBOARD OF DRIVER SEAT STANDARD HEATER PLUMBING WITH BALL SHUTOFF VALVES AT SUPPLY LINES ONLY RADIATOR MOUNTED AIR CONDITIONER CONDENSER PREMIUM INSULATION STANDARD LED CAB LIGHTING NO SECURITY DEVICE DOOR LOCKS AND IGNITION SWITCH KEYED THE SAME KEY QUANTITY OF 2 LH AND RH ELECTRIC DOOR LOCKS WITH AUTO UNLOCK FEATURE WHEN DOOR IS SET FROM OPEN TO CLOSED POSITION BRIGHT DOOR HANDLES TRIANGULAR REFLECTORS WITH FLARES PREMIUM 2.0 HIGH BACK AIR SUSPENSION DRIVER SEAT WITH 2 AIR LUMBAR, INTEGRATED CUSHION EXTENSION, TILT AND ADJUSTABLE SHOCK BATTERY BOX MID BACK NON SUSPENSION PASSENGER SEAT DUAL DRIVER SEAT ARMRESTS, NO PASSENGER SEAT ARMRESTS BLACK MORDURA CLOTH DRIVER SEAT COVER WITH EMBROIDERED LOGO BLACK MORDURA CLOTH PASSENGER SEAT COVER WITH NO LOGO



Prepared for:
Rick VanWassenhove
ELLIOTT EQUIPMENT CO
3100 W 76th Ave
Davenport, IA 52806
Phone: 563-391-4840



Prepared by:
Paul Moritz
TRANSWEST TRUCK TRAILER RV
20770 E. I-76 FRONTAGE ROAD
BRIGHTON, CO 80603
Phone: (303) 301-7409

Description

3 POINT ADJUSTABLE D-RING RETRACTOR
DRIVER AND FIXED D-RING RETRACTOR
PASSENGER SEAT BELTS

ADJUSTABLE TILT AND TELESCOPING
STEERING COLUMN

4-SPOKE 18 INCH (450MM) BLACK STEERING
WHEEL WITH SWITCHES

DRIVER AND PASSENGER INTERIOR SUN
VISORS

Instruments & Controls

STANDARD FOOT PEDAL SYSTEM
ELECTRONIC ACCELERATOR CONTROL
BLACK GAUGE BEZELS
STANDARD CENTER INSTRUMENT PANEL
DUAL NEEDLE PRIMARY AND SECONDARY AIR
PRESSURE GAUGE

INTAKE MOUNTED AIR RESTRICTION
INDICATOR WITHOUT GRADUATIONS

ELECTRONIC CRUISE CONTROL WITH
CONTROLS ON STEERING WHEEL SPOKES

KEY OPERATED IGNITION SWITCH AND
INTEGRAL START POSITION; 4 POSITION
OFF/RUN/START/ACCESSORY

PREMIUM INSTRUMENT CLUSTER WITH 5.0
INCH TFT COLOR DISPLAY

DIGITAL PANEL LAMP DIMMER SWITCH IN
DRIVER DISPLAY

HEAVY DUTY ONBOARD DIAGNOSTICS
INTERFACE CONNECTOR LOCATED BELOW LH
DASH

2 INCH ELECTRIC FUEL GAUGE

ENGINE REMOTE INTERFACE NOT
CONFIGURED

ELECTRICAL ENGINE COOLANT TEMPERATURE
GAUGE

NO ENGINE OIL TEMPERATURE GAUGE

ELECTRIC ENGINE OIL PRESSURE GAUGE

2 INCH TRANSMISSION OIL TEMPERATURE
GAUGE

ELECTRONIC OUTSIDE TEMPERATURE
SENSOR DISPLAY IN DRIVER MESSAGE
CENTER

ENGINE, TRIP AND PTO HOUR METERS
INTEGRAL WITHIN DRIVER DISPLAY



Prepared for:
Rick VanWassenhove
ELLIOTT EQUIPMENT CO
3100 W 76th Ave
Davenport, IA 52806
Phone: 563-391-4840



Prepared by:
Paul Moritz
TRANSWEST TRUCK TRAILER RV
20770 E. I-76 FRONTAGE ROAD
BRIGHTON, CO 80603
Phone: (303) 301-7409

	Description
	SELF CANCELING TURN SIGNAL SWITCH WITH DIMMER, HEADLAMP FLASH, WASH/WIPE/INTERMITTENT
	QUICKFIT POWERTRAIN INTERFACE CONNECTOR UNDER CAB WITH BLUNTCUTS
Design	
	PAINT: ONE SOLID COLOR
Color	
	CAB COLOR A: L0006EY WHITE ELITE EY BLACK, HIGH SOLIDS POLYURETHANE CHASSIS PAINT POWDER WHITE (N0006EA) REAR WHEELS/RIMS (PKWHT21, TKWHT21, W, TW)
Certification / Compliance	
	U.S. FMVSS CERTIFICATION, EXCEPT SALES CABS AND GLIDER KITS
Secondary Factory Options	
	CORPORATE PDI CENTER IN-SERVICE ONLY
Sales Programs	
	NO SALES PROGRAMS HAVE BEEN SELECTED
Extended Warranty	
	TOWING: 2 YEARS/UNLIMITED MILES/KM EXTENDED TOWING COVERAGE \$1200 CAP FEY APPLIES

(***) All cost increases for major components (Engines, Transmissions, Axles, Front and Rear Tires) and government mandated requirements, tariffs, and raw material surcharges will be passed through and added to factory invoices.

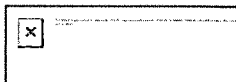

Prepared for:
 Rick VanWassenhove
 ELLIOTT EQUIPMENT CO
 3100 W 76th Ave
 Davenport, IA 52806
 Phone: 563-391-4840



Prepared by:
 Paul Moritz
 TRANSWEST TRUCK TRAILER RV
 20770 E. I-76 FRONTAGE ROAD
 BRIGHTON, CO 80603
 Phone: (303) 301-7409

DIMENSIONS

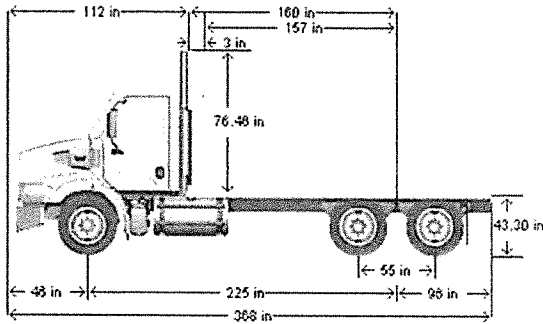

VEHICLE SPECIFICATIONS SUMMARY - DIMENSIONS

Model.....	47X
Wheelbase (545)	5725MM (225 INCH) WHEELBASE
Rear Frame Overhang (552)	2450MM (96 INCH) REAR FRAME OVERHANG
Fifth Wheel (578)	NO FIFTH WHEEL
Mounting Location (577).....	NO FIFTH WHEEL LOCATION
Maximum Forward Position (in).....	0
Maximum Rearward Position (in)	0
Amount of Slide Travel (in).....	0
Slide Increment (in).....	0
Desired Slide Position (in).....	0.0
Cab Size (829).....	111.6 INCH BBC CONVENTIONAL ALUMINUM CAB
Sleeper (682).....	NO SLEEPER BOX/SLEEPER CAB
Exhaust System (016).....	RH OUTBOARD UNDER STEP MOUNTED HORIZONTAL AFTERTREATMENT SYSTEM ASSEMBLY WITH RH B-PILLAR MOUNTED VERTICAL TAILPIPE

TABLE SUMMARY - DIMENSIONS



Prepared for:
 Rick VanWassenhove
 ELLIOTT EQUIPMENT CO
 3100 W 76th Ave
 Davenport, IA 52806
 Phone: 563-391-4840



Prepared by:
 Paul Moritz
 TRANSWEST TRUCK TRAILER RV
 20770 E. I-76 FRONTAGE ROAD
 BRIGHTON, CO 80603
 Phone: (303) 301-7409

Dimensions	Inches
Bumper to Back of Cab (BBC)	111.6
Bumper to Centerline of Front Axle (BA)	46.5
Front Axle to Back of Cab (AC)	65.2
Min. Cab to Body Clearance (CB)	3.0
Back of Cab to Centerline of Rear Axle(s) (CA)	160.2
Effective Back of Cab to Centerline of Rear Axle(s) (Effective CA)	157.2
Back of Cab Protrusions (Exhaust/Intake) (CP)	2.0
Back of Cab Protrusions (Side Extenders/Trim Tab) (CP)	0.0
Back of Cab Protrusions (CNG Tank)	0.0
Back of Cab Clearance (CL)	3.0
Back of Cab to End of Frame	256.7
Cab Height (CH)	75.5
Wheelbase (WB)	225.4
Frame Overhang (OH)	96.5
Overall Frame Length	367.1
Overall Length (OAL)	368.4
Rear Axle Spacing	55.0
Unladen Frame Height at Centerline of Rear Axle	43.3

Performance calculations are estimates only. If performance calculations are critical, please contact Customer Application Engineering.



Prepared for:
Rick VanWassenhove
ELLIOTT EQUIPMENT CO
3100 W 76th Ave
Davenport, IA 52806
Phone: 563-391-4840



Prepared by:
Paul Moritz
TRANSWEST TRUCK TRAILER RV
20770 E. I-76 FRONTAGE ROAD
BRIGHTON, CO 80603
Phone: (303) 301-7409

G V W R

VEHICLE SPECIFICATIONS SUMMARY - GVWR

Model 47X
Cab Size (829) 111.6 INCH BBC CONVENTIONAL ALUMINUM CAB
Expected Front Axle(s) Load (lbs) 18000.0
Expected Pusher Axle(s) Load (lbs) 0.0
Expected Rear Axle(s) Load (lbs) 46000.0
Expected Tag Axle(s) Load (lbs) 0.0
Expected GVW (lbs) 64000
Expected GCW (lbs) 0.0
Front Axle (400) DETROIT DA-F-18.0-5 18,000# FL1 71.0 KPI/3.74 DROP SINGLE FRONT AXLE
Front Suspension (620) 20,000# TAPERLEAF FRONT SUSPENSION
Front Hubs (418) CONMET PRESET PLUS PREMIUM IRON FRONT HUBS
Front Disc Wheels (502) ALCOA LVL ONE 82462X 22.5X12.25 10-HUB PILOT 4.68 INSET 10-HAND ALUMINUM DISC FRONT WHEELS
Front Tires (093) MICHELIN XZY-3 385/65R22.5 18 PLY RADIAL FRONT TIRES
Front Brakes (402) MERITOR 16.5X6 Q+ CAST SPIDER CAM FRONT BRAKES, DOUBLE ANCHOR, FABRICATED SHOES
Steering Gear (536) DUAL POWER STEERING GEARS, BENDIX 16-20K
Rear Axle (420) RT-46-160P 46,000# R-SERIES TANDEM REAR AXLE
Rear Suspension (622) TUFTRAC GEN2 46,000# REAR SPRING SUSPENSION
Rear Hubs (450) CONMET PRESET PLUS PREMIUM IRON REAR HUBS
Rear Disc Wheels (505) .. ALCOA LVL ONE 88267X ALUMINUM OUTSIDE, ACCURIDE 51637 STEEL INSIDE; 22.5X8.25 10-HUB PILOT DISC REAR WHEELS
Rear Tires (094) MICHELIN X WORKS D 11R22.5 16 PLY RADIAL REAR TIRES
Rear Brakes (423) MERITOR 16.5X7 Q+ CAST SPIDER CAM REAR BRAKES, DOUBLE ANCHOR, FABRICATED SHOES
Pusher / Tag Axle (443) NO PUSHER OR TAG AXLE
Pusher / Tag Suspension (626) NO PUSHER OR TAG SUSPENSION
Pusher / Tag Hubs (449) NO PUSHER OR TAG HUBS
Pusher/Tag Disc Wheels (509) NO PUSHER/TAG DISC WHEELS
Pusher / Tag Tires (095) NO PUSHER/TAG TIRES
Pusher / Tag Brakes (456) NO PUSHER/TAG BRAKES



Prepared for:
 Rick VanWassenhove
 ELLIOTT EQUIPMENT CO
 3100 W 76th Ave
 Davenport, IA 52806
 Phone: 563-391-4840



Prepared by:
 Paul Moritz
 TRANSWEST TRUCK TRAILER RV
 20770 E. I-76 FRONTAGE ROAD
 BRIGHTON, CO 80603
 Phone: (303) 301-7409

TABLE SUMMARY - GVWR

	Front	Rear 1	Rear 2
Axle Component Weight Ratings			
Axles	18000	23000	23000
Suspension	20000	23000	23000
Hubs	23000	26000	26000
Brakes	20000	23000	23000
Wheels	24600	29600	29600
Tires	18740	24020	24020
Power Steering	20000	N/A	N/A
GAWR (per axle)	18000	23000	23000
GAWR (per axle system)	18000		46000
Expected Load (per axle system)	18000		46000
GVWR due to Frame	90000		
GVWR due to Transmission	62000		
Vehicle GVWR Summary			
Calculated GVWR	64000		
Expected GVWR	64000		
All weights displayed in pounds			

Performance calculations are estimates only. If performance calculations are critical, please contact Customer Application Engineering.



COBRA[®]



THE HUNT IS OVER

With the largest body capacity in New Way's rear loader lineup, the Cobra Magnum[®] is designed to offer the easiest operational features available in today's market. Operators have convenient access to curbside hydraulic controls on this impressive rear loader that will easily compact approximately 1,000+ lbs per yd³.

COBRA[®] Magnum

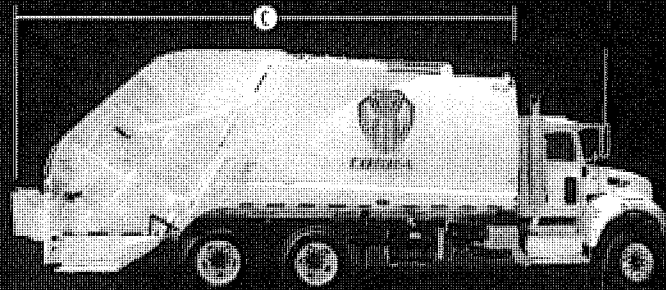
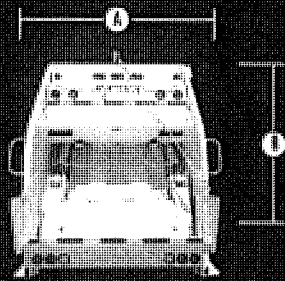

GENERAL SPECIFICATIONS

Model	20 CM	25 CM	27 CM	32 CM
Body Capacity	20 yd ³	25 yd ³	27 yd ³	32 yd ³
Hopper Capacity	3.55 yd ³	3.55 yd ³	3.55 yd ³	3.55 yd ³
Body Width (A)	98"	98"	98"	98"
Body Height (B)	100"	100"	100"	100"
‡ Body Length (C)	263"	285"	296"	315.5"
* Approx. Body Weight	14,880 lbs	15,950 lbs	15,490 lbs	16,550 lbs
Hopper Opening Width	80"	80"	80"	80"
Loading Sill Height	3.5' (60" frame)	3.5' (60" frame)	3.5' (60" frame)	3.5' (60" frame)
Hopper Cycle Time	21-23 secs.	21-23 secs.	21-23 secs.	21-23 secs.

MINIMUM CHASSIS SPECIFICATIONS

* Minimum GVWR	55,000 lbs	60,000 lbs	62,000 lbs	64,000 lbs
Cab to Trunnion	140"	160"	172"	204"

HYDRAULIC CYLINDER SPECIFICATIONS

Slide Cylinders (2)	5"	5"	5"	5"
Sweep Cylinders (2)	4.5"	4.5"	4.5"	4.5"
Tailgate Cylinders (2)	4.5"	4.5"	4.5"	4.5"
Ejection Cylinder	4.5" x 7.5"	4.5" x 7.5"	4.5" x 7.5"	4.5" x 7.5"

BODY CONSTRUCTION

Roof & Sides	14 gauge	60K GR
Floor (front)	10 gauge	50K GR
Floor (rear)	7 gauge	100K GR
Ejection Panel	10 gauge	50K GR
Sweep Panel	12"	70K GR
Tailgate (upper)	10 gauge	50K GR
Tailgate (lower)	12"	100K GR
Hopper Floor (back)	14"	100K GR
Side Panel	7 gauge	100K GR

HYDRAULIC SYSTEMS

Oil Reservoir	65 gal
Oil Flow w/ std. pump	31 gpm
Max Operating Pressure	2,750 psi
Engine RPM for STD gpm	1,312-1,511
Hydraulic Hoses	4 x 1 1/2"
Return Filter	10 micron

STANDARD EQUIPMENT

- Semi-automatic cycling
- Auto brake pack
- Accelerator kit
- Back up alarm
- Turn handle lock
- LED lights
- Upper rear lights
- Right gauge on oil tank
- Chrome cylinder rods
- Side access door
- Bulwer alert buzzer
- Tailgate door indicator
- Riding steps on rear
- Front drive protective panel
- Color rear view camera system
- Telematic Extreme hydraulic filter

OPTIONAL EQUIPMENT

- Spot lighting
- 210 & 240
- Camera (left, rear, mirror & external)
- ABS brake system
- Hopper door
- External mirrors
- ABS modulator

† Length measurement depends on options ordered.

* Approximate Body Weight empty and exclusive of options.

** Any Chassis sent to Structural Manufacturing with less than the minimum guideline requirements will not be mounted. (Chassis must be capable of carrying the net weight of the body plus the weight of the refuse collected.)

AUTHORIZED NEW WAY DISTRIBUTOR



NEW WAY[®] Driving The Difference[®]

A quality product of **McLaughlin BAWLY COMPANIES** • 800 831 1858 • www.newwaytrucks.com



Missouri Public Entity Risk Management Fund
 3425 Constitution Ct., 3rd Floor
 P.O. Box 7110
 Jefferson City, MO 65102-7110



Central Bank
 P.O. Box 779
 Jefferson City, Missouri 65102
 80-63/865

36347

12/01/2023

TWO HUNDRED SEVEN THOUSAND THREE HUNDRED SIXTY-FOUR AND 95 / 100

\$ 207,364.95

DOLLARS

PAY
TO THE
ORDER OF

CITY OF SEDALIA
200 S OSAGE
SEDALIA MO 65301

Void After 90 Days
TWO SIGNATURES REQUIRED



Brenda L Gibson
Terri Collins
AUTHORIZED SIGNATURE

MEMO

Claim Payments

⑈036347⑈ ⑆086500634⑆ ⑈10 1799 3⑈

MOPERM

12/01/2023

36347

Claim Number	Claimant	Member Name	Description	Amount
AP23-0048906-1	CITY OF SEDALIA	CITY OF SEDALIA	Claim AP23-0048906-1 from CITY OF SEDALIA 2022 INTERNATIONAL REAR LOAD REFUSE TRUCK 3HAEJTAN2NL169005 Attention Jason Meyers Total loss payment ACV \$208,364.95- \$1000 deductible	\$208,364.95
AP23-0048906-1	CITY OF SEDALIA	CITY OF SEDALIA	Deductible Applied	-\$1,000.00
			Total	\$207,364.95

BILL NO. _____

ORDINANCE NO. _____

AN ORDINANCE AUTHORIZING AN ANNEXATION AND UTILITY SERVICES AGREEMENT FOR CONNECTION TO THE CITY OF SEDALIA'S WATER DISTRIBUTION SYSTEM.

WHEREAS, The City of Sedalia, Missouri, has received an annexation and utility services agreement from Kroeger Properties II, LLC; and

WHEREAS, under the agreement, the City of Sedalia, Missouri agrees to allow Kroeger Properties II, LLC to connect property at 6025 Lowe Drive that is located outside of the city limits of Sedalia to the City of Sedalia's water distribution system as more fully described in the proposed agreement attached and incorporated by reference as though the proposed agreement were set forth herein.

NOW THEREFORE, BE IT ORDAINED BY THE COUNCIL OF THE CITY OF SEDALIA, MISSOURI, as follows:

Section 1. The Council of the City of Sedalia, Missouri, hereby approves and accepts the agreement by and between the City of Sedalia, Missouri and Kroeger Properties II, LLC in substantively the same form and content as the agreement has been proposed.

Section 2. The Mayor is authorized and directed to execute and the City Clerk is hereby authorized and directed to attest and fix the seal of the City of Sedalia, Missouri, on the document in substantively the same form and content as it has been proposed.

Section 3. The City Clerk is hereby directed to file in his office a duplicate or copy of the document after it has been executed by the parties or their duly authorized representatives and after said agreement has been recorded with the Pettis County Recorder of Deed's office.

Section 4. This ordinance shall take effect and be in full force and effect from and after its passage and approval.

Read two times by title, copies of the proposed ordinance having been made available for public inspection prior to the time the bill is under consideration by the Council and passed by the Council of the City of Sedalia, Missouri this 18th day of December, 2023.

Presiding Officer of the Council

Approved by the Mayor of said City this 18th day of December, 2023.

Andrew L. Dawson, Mayor

ATTEST:

Jason S. Myers
City Clerk



Let's Cross Paths

City of Sedalia

200 S. Osage

Sedalia, MO 65301

(660) 827-3000 www.sedalia.com

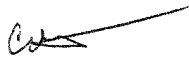
To: Kelvin Shaw, City Administrator
Through: Chris Davies, Public Works Director 
From: Elizabeth Nations, Executive Administrative Assistant
Date: December 4, 2023
Subject: Annexation Agreement for Water Service

Please find attached an annexation agreement between the City of Sedalia and Kroeger Properties II LLC for Lot number Three (3) for Walnut Park 3 to be addressed as 6025 Lowe Dr. Kroeger Properties II LLC is requesting connection to the City's water distribution system and has agreed to pay the "out of City limits" rates until such time as the property is annexed into the City.

The agreement is written to allow the City to disconnect the water line should Kroeger Properties II LLC not complete the annexation process. Kroeger Properties II LLC has already signed and had notarized the agreement.

ANNEXATION AND UTILITY SERVICES AGREEMENT

This Agreement (hereinafter "Agreement") entered into this 4th day of December, 2023, between the City of Sedalia, Missouri, (hereinafter "City") and Kroeger Properties II, LLC (hereinafter "Owner").

RECITALS:

1. Whereas, Owner represents that he is the owner of the following real estate (hereinafter referred as "Owner's real estate") located in Pettis County, Missouri:

See attached "Exhibit A" as legal description of property and "Exhibit B" for location of property.

2. Whereas, Owner desires to connect Owner's property to the City's water system for purposes of developing Owner's property; and

3. Whereas, City desires to permit Owner to connect to the City's water system for purposes of developing Owner's property; and

4. Whereas, City desires the right to annex Owner's property if Owner's property becomes contiguous to City's corporate city limits; and

NOW, THEREFORE, for and in consideration of the above-recitals as well as the terms and conditions hereafter, the parties hereby agree as follows:

1. Owner, in exchange for the City's agreement to allow Owner to connect his property to the City's water system, the Owner, on behalf of himself, his successors, heirs and assigns, hereby conveys unto the City the irrevocable and perpetual right to file on his behalf a Petition of Annexation at any time after annexation becomes possible.

2. City shall allow Owner to connect a water line serving Owner's property to the City's water system, and Owner shall make connection at his expense. Prior to approving the physical connection, Owner shall obtain all necessary easements, if needed, from any other landowners and provide recorded copies to the City, obtain permits for the connection and pay all fees required to connect to the City's water system. City shall provide and install water meter and box for connection of Owner's water service line. Owner shall be responsible for connecting the Owner's water service line from the house to the meter. Owner shall become a utility customer of the City and shall pay all fees and charges established by the City for water service.

3. The Owner shall ensure the water service line serving Owner's property is constructed in compliance with City regulations and standards. Construction of the water service line shall be

inspected by the City as though the property were within the City limits and shall be subject to City approval. Owner agrees to bring the new water service line to the City's meter and make connection. Owner shall not be charged for water service until the activation of service with the City of Sedalia.

4. Owner agrees to the "out of city limits" fee/cost schedule for services until such time as the Owner's property is annexed into the City of Sedalia.

5. Water service lines serving property other than the Owner's property shall not be connected to the line serving the Owner's property without the City's written consent.

6. To the extent allowed by law, the City may annex Owner's property into the City, without further action of the Owner, after Owner's property becomes contiguous to the corporate limits of the City.

7. Owner irrevocably appoint the City Administrator of Sedalia, Missouri, as its attorney-in- fact for the sole purpose of presenting a verified petition requesting annexation of Owner's property to the City Council of Sedalia, Missouri, IF AND WHEN the property becomes contiguous and compact to the city limits of the City of Sedalia, Missouri. The City Administrator may exercise this power of attorney at any time after Owner's property becomes contiguous to the corporate limits of the City. Owner on his behalf, and on behalf of his heirs, successors and assigns do hereby waive any notice of the filing of the petition, do hereby consent to the granting of the petition, and do hereby waive any objections, statutory or otherwise, to the annexation of the property into the City of Sedalia. Owner does hereby authorize the City to take whatever action necessary to complete the annexation of this property. Owner's consent to such future annexation of the Property is irrevocable.

8. The parties hereto agree that this Agreement shall be recorded, in the real estate records of the Office of Recorder of Deeds of Pettis County, Missouri, and that the obligations and conditions of this Agreement shall run with the Property and shall be binding upon all future owners and users of the Property. Owner, on his own behalf and on behalf of all such future owners of the Property hereby agree that each purchaser, assignee or transferee of an interest in the Property, or any portion thereof, will be obligated and bound by the terms of this Agreement. Owner, on his own behalf and on behalf of all future owners of the Property, acknowledges that he and /or future owners of the Property shall be responsible for payment of all properly billed fees for water service as established by the City of Sedalia. Owner's liability contained in this paragraph 8 shall terminate when Owner has transferred his ownership interest in Owner's property to a successor owner, at which time, the successor owner shall be responsible for payment of all properly billed fees for water service as established by the City of Sedalia.

9. Alternatively, if requested by the City Administrator, Owner, his successors, assigns and heirs shall, within such time as specified by the City Administrator, submit a verified petition requesting annexation of the Owner's property to the City Clerk for presentation to the City Council of Sedalia, Missouri. The City Administrator may request Owner to present an annexation petition at any time after Owner's property becomes contiguous to the corporate limits of the City. The provisions of this paragraph shall be enforceable by specific performance.

10. Owner shall give a copy of this Agreement to the person or persons who buy the Owner's property.

11. If Owner fails to comply with any of the provisions of this Agreement, or repudiate the

terms of this Agreement, City may terminate water service to Owner's property and disconnect the utility lines serving Owner's property from the City's water system. City shall give Owner six months prior written notice of its intent to terminate service.

12. This Agreement is not intended to confer any rights or remedies on any person other than the parties.

13. The benefits and burdens of this Agreement are intended to attach to and run with the land and shall be binding on and inure to the benefit of the parties and their respective legal representatives, successors, heirs and assigns. All persons claiming under the parties shall conform to and observe the provisions of this Agreement.

14. This Agreement shall be recorded in the office of the Pettis County Recorder of Deeds at the City's expense.

IN WITNESS WHEREOF, the parties have executed this Agreement on the day and year first above written.

CITY OF SEDALIA, MISSOURI

By:

Andrew Dawson, Mayor

ATTEST:

Jason Myers, City Clerk

OWNER: KROEGER PROPERTIES II LLC

By: 

John K. Kroeger, Authorized Representative

On the _____ day of _____, 2023 before me appeared _____, to me personally known, who, being by me duly sworn, did say that he is the Mayor of the City of Sedalia, Missouri , and that the seal affixed to the foregoing instrument is the corporate seal of the City and that this instrument was signed and sealed on behalf of the City by authority of its City Council and the Mayor acknowledged this instrument to be the free act and deed of the City.

IN TESTIMONY WHEREOF, I have hereunto set by hand and affixed my official seal my office in Sedalia, Pettis County, Missouri, the day and year first above written.

By: _____
Andrew Dawson, Mayor

ACKNOWLEDGMENT BY OWNER, CORPORATION OR ASSOCIATION

STATE OF MISSOURI)
) ss
COUNTY OF PETTIS)

On the day 4th of Dec., 2023, before me appeared John K. Kroeger Kroeger Properties II, LLC to me personally known, who, being by me duly sworn, did say that he is the Owner of _____ and that said instrument was signed by him and acknowledged the said instrument to be a free act and deed of _____.

IN TESTIMONY WHEREOF, I have hereunto set my hand and affixed my official seal in the County and state aforesaid the day and year first above written.

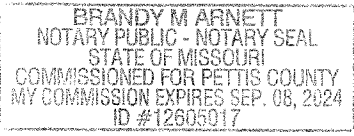

Brandy M Arnett

Notary Public

Exhibit A

See Attached Warranty Deed recorded as Document 2022-1304 by the Pettis County Recorder of Deeds.

2022-1304

RECORDED ON
03/10/2022 01:17 PM
PAGES: 2

**BARBARA CLEVINGER
RECORDER OF DEEDS
PETTIS COUNTY, MO**

MISSOURI WARRANTY DEED

This Deed, Made and entered into this 10th day of March, 2022, by and between

MONSEES REALTY COMPANY, LLC, as "GRANTOR",

and

JOHN K KROEGER CONSTRUCTION, LLC, as "GRANTEE",

Grantee's mailing address: 24545 DEER RUN DR, SMITHTON, MO 65350

WITNESSETH, that the Grantor, in consideration of the sum of Ten Dollars (\$10.00) and other valuable consideration paid by the Grantee, the receipt and sufficiency of which is hereby acknowledged, does hereby GRANT, BARGAIN AND SELL, CONVEY AND CONFIRM unto Grantee, the following described Real Estate, situated in the County of Pettis and State of Missouri, to wit:

ALL OF LOT NUMBER THREE (3) OF WALNUT PARK 3, BEING A RESURVEY OF PART OF TRACT "A" OF SOUTH WALNUT HILLS, PETTIS COUNTY, MISSOURI.

Subject to easements, restrictions, reservations, and covenants of record, if any.

TO HAVE AND TO HOLD the premises aforesaid with all singular, the rights, privileges, appurtenances and immunities thereto belonging or in any wise appertaining unto Grantee and unto Grantee's heirs and assigns forever; the Grantor hereby covenanting that Grantor is lawfully seized of an indefeasible estate in fee of the premises herein conveyed; that Grantor has good right to convey the same; that the said premises are free and clear from any encumbrance done or suffered by Grantor or those under whom Grantor claims, except as stated above and except for all taxes and assessments, general and special, not now due and payable, and that Grantor will warrant and defend the title to the said premises unto Grantee and unto Grantee's heirs and assigns forever, against the lawful claims and demands of all persons whomsoever. If two or more persons constitute the Grantor or Grantee, the words Grantor and Grantee will be construed to read Grantors and Grantees whenever the sense of this Deed requires.

22031041

LEGAL DESCRIPTION

6025 LOWE DR.

Tract A: LOT 3 IN WALNUT PARK 3 BEING A RESURVEY OF TRACT 'A' OF SOUTH WALNUT HILLS, PETTIS COUNTY MISSOURI

6027 LOWE DR.

Tract B: LOT 3 IN WALNUT PARK 3 BEING A RESURVEY OF TRACT 'B' OF SOUTH WALNUT HILLS, PETTIS COUNTY MISSOURI.

Exhibit B

Location of Property
6025 Lowe Dr.

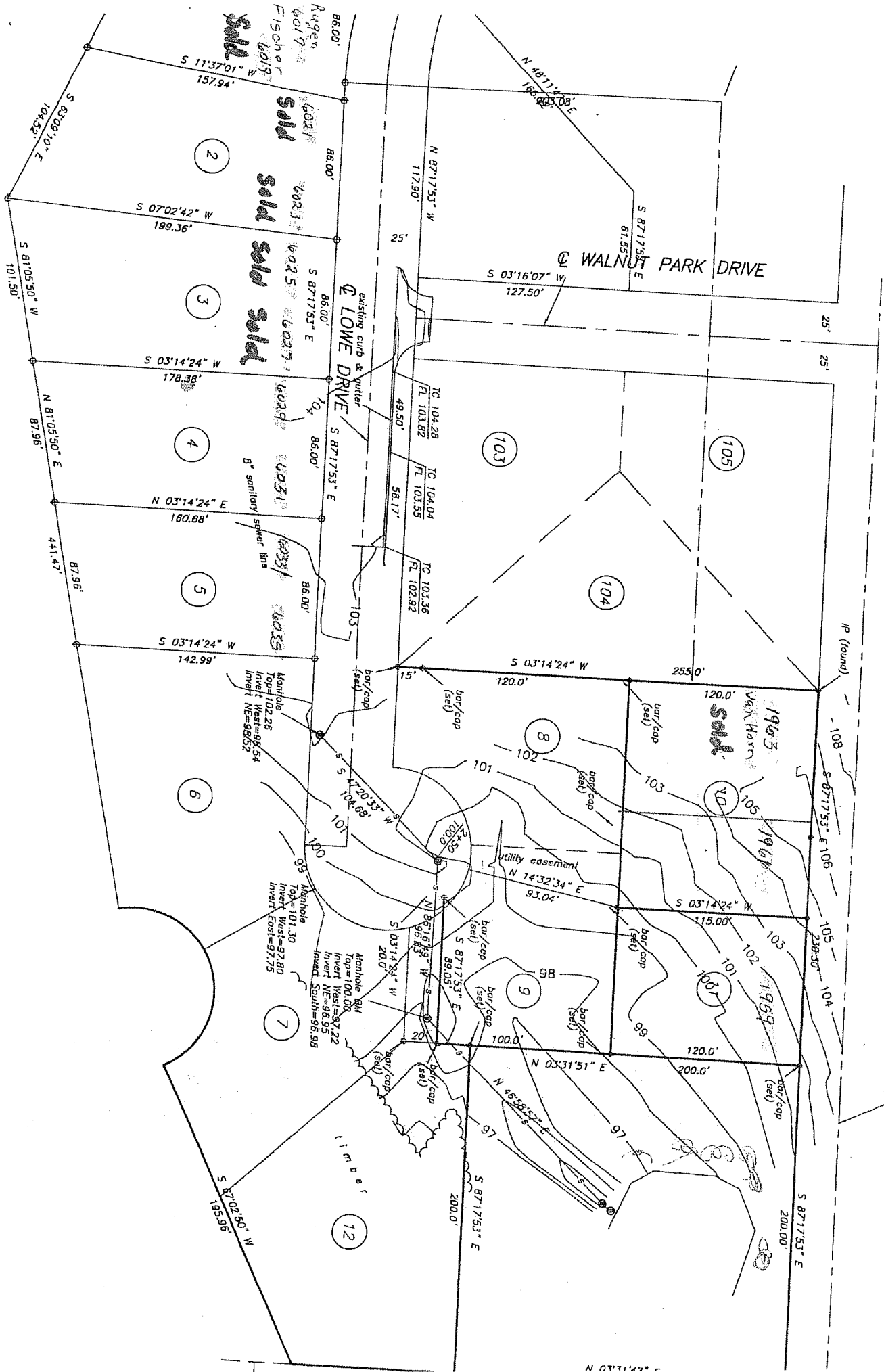

BILL NO. _____

ORDINANCE NO. _____

AN ORDINANCE AUTHORIZING AN ANNEXATION AND UTILITY SERVICES AGREEMENT FOR CONNECTION TO THE CITY OF SEDALIA'S WATER DISTRIBUTION SYSTEM.

WHEREAS, The City of Sedalia, Missouri, has received an annexation and utility services agreement from Kroeger Properties II, LLC; and

WHEREAS, under the agreement, the City of Sedalia, Missouri agrees to allow Kroeger Properties II, LLC to connect property at 6027 Lowe Drive that is located outside of the city limits of Sedalia to the City of Sedalia's water distribution system as more fully described in the proposed agreement attached and incorporated by reference as though the proposed agreement were set forth herein.

NOW THEREFORE, BE IT ORDAINED BY THE COUNCIL OF THE CITY OF SEDALIA, MISSOURI, as follows:

Section 1. The Council of the City of Sedalia, Missouri, hereby approves and accepts the agreement by and between the City of Sedalia, Missouri and Kroeger Properties II, LLC in substantively the same form and content as the agreement has been proposed.

Section 2. The Mayor is authorized and directed to execute and the City Clerk is hereby authorized and directed to attest and fix the seal of the City of Sedalia, Missouri, on the document in substantively the same form and content as it has been proposed.

Section 3. The City Clerk is hereby directed to file in his office a duplicate or copy of the document after it has been executed by the parties or their duly authorized representatives and after said agreement has been recorded with the Pettis County Recorder of Deed's office.

Section 4. This ordinance shall take effect and be in full force and effect from and after its passage and approval.

Read two times by title, copies of the proposed ordinance having been made available for public inspection prior to the time the bill is under consideration by the Council and passed by the Council of the City of Sedalia, Missouri this 18th day of December, 2023.

Presiding Officer of the Council

Approved by the Mayor of said City this 18th day of December, 2023.

Andrew L. Dawson, Mayor

ATTEST:

Jason S. Myers
City Clerk



Let's Cross Paths

City of Sedalia

200 S. Osage

Sedalia, MO 65301

(660) 827-3000 www.sedalia.com

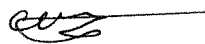
To: Kelvin Shaw, City Administrator
Through: Chris Davies, Public Works Director 
From: Elizabeth Nations, Executive Administrative Assistant
Date: December 4, 2023
Subject: Annexation Agreement for Water Service

Please find attached an annexation agreement between the City of Sedalia and Kroeger Properties II LLC for Lot number Three (3) for Walnut Park 3 to be addressed as 6027 Lowe Dr. Kroeger Properties II LLC is requesting connection to the City's water distribution system and has agreed to pay the "out of City limits" rates until such time as the property is annexed into the City.

The agreement is written to allow the City to disconnect the water line should Kroeger Properties II LLC not complete the annexation process. Kroeger Properties II LLC has already signed and had notarized the agreement.

ANNEXATION AND UTILITY SERVICES AGREEMENT

This Agreement (hereinafter "Agreement") entered into this 4th day of December, 2023, between the City of Sedalia, Missouri, (hereinafter "City") and Kroeger Properties II, LLC (hereinafter "Owner").

RECITALS:

1. Whereas, Owner represents that he is the owner of the following real estate (hereinafter referred as "Owner's real estate") located in Pettis County, Missouri:

See attached "Exhibit A" as legal description of property and "Exhibit B" for location of property.

2. Whereas, Owner desires to connect Owner's property to the City's water system for purposes of developing Owner's property; and

3. Whereas, City desires to permit Owner to connect to the City's water system for purposes of developing Owner's property; and

4. Whereas, City desires the right to annex Owner's property if Owner's property becomes contiguous to City's corporate city limits; and

NOW, THEREFORE, for and in consideration of the above-recitals as well as the terms and conditions hereafter, the parties hereby agree as follows:

1. Owner, in exchange for the City's agreement to allow Owner to connect his property to the City's water system, the Owner, on behalf of himself, his successors, heirs and assigns, hereby conveys unto the City the irrevocable and perpetual right to file on his behalf a Petition of Annexation at any time after annexation becomes possible.

2. City shall allow Owner to connect a water line serving Owner's property to the City's water system, and Owner shall make connection at his expense. Prior to approving the physical connection, Owner shall obtain all necessary easements, if needed, from any other landowners and provide recorded copies to the City, obtain permits for the connection and pay all fees required to connect to the City's water system. City shall provide and install water meter and box for connection of Owner's water service line. Owner shall be responsible for connecting the Owner's water service line from the house to the meter. Owner shall become a utility customer of the City and shall pay all fees and charges established by the City for water service.

3. The Owner shall ensure the water service line serving Owner's property is constructed in compliance with City regulations and standards. Construction of the water service line shall be

inspected by the City as though the property were within the City limits and shall be subject to City approval. Owner agrees to bring the new water service line to the City's meter and make connection. Owner shall not be charged for water service until the activation of service with the City of Sedalia.

4. Owner agrees to the "out of city limits" fee/cost schedule for services until such time as the Owner's property is annexed into the City of Sedalia.

5. Water service lines serving property other than the Owner's property shall not be connected to the line serving the Owner's property without the City's written consent.

6. To the extent allowed by law, the City may annex Owner's property into the City, without further action of the Owner, after Owner's property becomes contiguous to the corporate limits of the City.

7. Owner irrevocably appoint the City Administrator of Sedalia, Missouri, as its attorney-in- fact for the sole purpose of presenting a verified petition requesting annexation of Owner's property to the City Council of Sedalia, Missouri, IF AND WHEN the property becomes contiguous and compact to the city limits of the City of Sedalia, Missouri. The City Administrator may exercise this power of attorney at any time after Owner's property becomes contiguous to the corporate limits of the City. Owner on his behalf, and on behalf of his heirs, successors and assigns do hereby waive any notice of the filing of the petition, do hereby consent to the granting of the petition, and do hereby waive any objections, statutory or otherwise, to the annexation of the property into the City of Sedalia. Owner does hereby authorize the City to take whatever action necessary to complete the annexation of this property. Owner's consent to such future annexation of the Property is irrevocable.

8. The parties hereto agree that this Agreement shall be recorded, in the real estate records of the Office of Recorder of Deeds of Pettis County, Missouri, and that the obligations and conditions of this Agreement shall run with the Property and shall be binding upon all future owners and users of the Property. Owner, on his own behalf and on behalf of all such future owners of the Property hereby agree that each purchaser, assignee or transferee of an interest in the Property, or any portion thereof, will be obligated and bound by the terms of this Agreement. Owner, on his own behalf and on behalf of all future owners of the Property, acknowledges that he and /or future owners of the Property shall be responsible for payment of all properly billed fees for water service as established by the City of Sedalia. Owner's liability contained in this paragraph 8 shall terminate when Owner has transferred his ownership interest in Owner's property to a successor owner, at which time, the successor owner shall be responsible for payment of all properly billed fees for water service as established by the City of Sedalia.

9. Alternatively, if requested by the City Administrator, Owner, his successors, assigns and heirs shall, within such time as specified by the City Administrator, submit a verified petition requesting annexation of the Owner's property to the City Clerk for presentation to the City Council of Sedalia, Missouri. The City Administrator may request Owner to present an annexation petition at any time after Owner's property becomes contiguous to the corporate limits of the City. The provisions of this paragraph shall be enforceable by specific performance.

10. Owner shall give a copy of this Agreement to the person or persons who buy the Owner's property.

11. If Owner fails to comply with any of the provisions of this Agreement, or repudiate the

terms of this Agreement, City may terminate water service to Owner's property and disconnect the utility lines serving Owner's property from the City's water system. City shall give Owner six months prior written notice of its intent to terminate service.

12. This Agreement is not intended to confer any rights or remedies on any person other than the parties.

13. The benefits and burdens of this Agreement are intended to attach to and run with the land and shall be binding on and inure to the benefit of the parties and their respective legal representatives, successors, heirs and assigns. All persons claiming under the parties shall conform to and observe the provisions of this Agreement.

14. This Agreement shall be recorded in the office of the Pettis County Recorder of Deeds at the City's expense.

IN WITNESS WHEREOF, the parties have executed this Agreement on the day and year first above written.

CITY OF SEDALIA, MISSOURI

By :

Andrew Dawson, Mayor

ATTEST:

Jason Myers, City Clerk

OWNER: KROEGER PROPERTIES II LLC

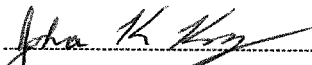
By : 

John K. Kroeger, Authorized Representative

Exhibit A

See Attached Warranty Deed recorded as Document 2022-1304 by the Pettis County Recorder of Deeds.

2022-1304

RECORDED ON
03/10/2022 01:17 PM
PAGES: 2

**BARBARA CLEVINGER
RECORDER OF DEEDS
PETTIS COUNTY, MO**

MISSOURI WARRANTY DEED

This Deed, Made and entered into this 10th day of March, 2022, by and between

MONSEES REALTY COMPANY, LLC, as "GRANTOR",

and

JOHN K KROEGER CONSTRUCTION, LLC, as "GRANTEE",

Grantee's mailing address: 24545 DEER RUN DR, SMITHTON, MO 65350

WITNESSETH, that the Grantor, in consideration of the sum of Ten Dollars (\$10.00) and other valuable consideration paid by the Grantee, the receipt and sufficiency of which is hereby acknowledged, does hereby GRANT, BARGAIN AND SELL, CONVEY AND CONFIRM unto Grantee, the following described Real Estate, situated in the County of Pettis and State of Missouri, to wit:

ALL OF LOT NUMBER THREE (3) OF WALNUT PARK 3, BEING A RESURVEY OF PART OF TRACT "A" OF SOUTH WALNUT HILLS, PETTIS COUNTY, MISSOURI.

Subject to easements, restrictions, reservations, and covenants of record, if any.

TO HAVE AND TO HOLD the premises aforesaid with all singular, the rights, privileges, appurtenances and immunities thereto belonging or in any wise appertaining unto Grantee and unto Grantee's heirs and assigns forever; the Grantor hereby covenanting that Grantor is lawfully seized of an indefeasible estate in fee of the premises herein conveyed; that Grantor has good right to convey the same; that the said premises are free and clear from any encumbrance done or suffered by Grantor or those under whom Grantor claims, except as stated above and except for all taxes and assessments, general and special, not now due and payable, and that Grantor will warrant and defend the title to the said premises unto Grantee and unto Grantee's heirs and assigns forever, against the lawful claims and demands of all persons whomsoever. If two or more persons constitute the Grantor or Grantee, the words Grantor and Grantee will be construed to read Grantors and Grantees whenever the sense of this Deed requires.

22031041

IN WITNESS WHEREOF, the Grantor has hereunto executed this instrument on the day and year above written.

MONSEES REALTY COMPANY, LLC

By: *A.B. Monsees*
A.B. MONSEES, MANAGER

STATE OF MISSOURI }
 } ss:
COUNTY OF PETTIS }

On this 10th day of March, 2022, before me, the undersigned, a Notary Public in and for said County and State, personally appeared A.B. MONSEES, to me personally known, who being by me duly sworn, did say that he is the Manager of MONSEES REALTY COMPANY, LLC, a Missouri Limited Liability Company, and that said instrument was signed on behalf of said Limited Liability Company, and said Manager acknowledged said instrument to be the free act and deed of said Limited Liability Company.

IN WITNESS WHEREOF, I have hereunto set my hand and affixed my notarial seal in the County and State aforesaid, the day and year last above written.

Jennifer L. Huhmann
Notary Public

My Term Expires:

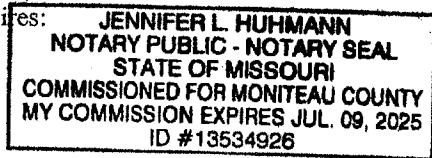

LEGAL DESCRIPTION

6025 LOWE DR.

Tract A: LOT 3 IN WALNUT PARK 3 BEING A RESURVEY OF TRACT 'A' OF SOUTH WALNUT HILLS, PETTIS COUNTY MISSOURI

6027 LOWE DR.

Tract B: LOT 3 IN WALNUT PARK 3 BEING A RESURVEY OF TRACT 'B' OF SOUTH WALNUT HILLS, PETTIS COUNTY MISSOURI.

Exhibit B

Location of Property
6027 Lowe Dr.

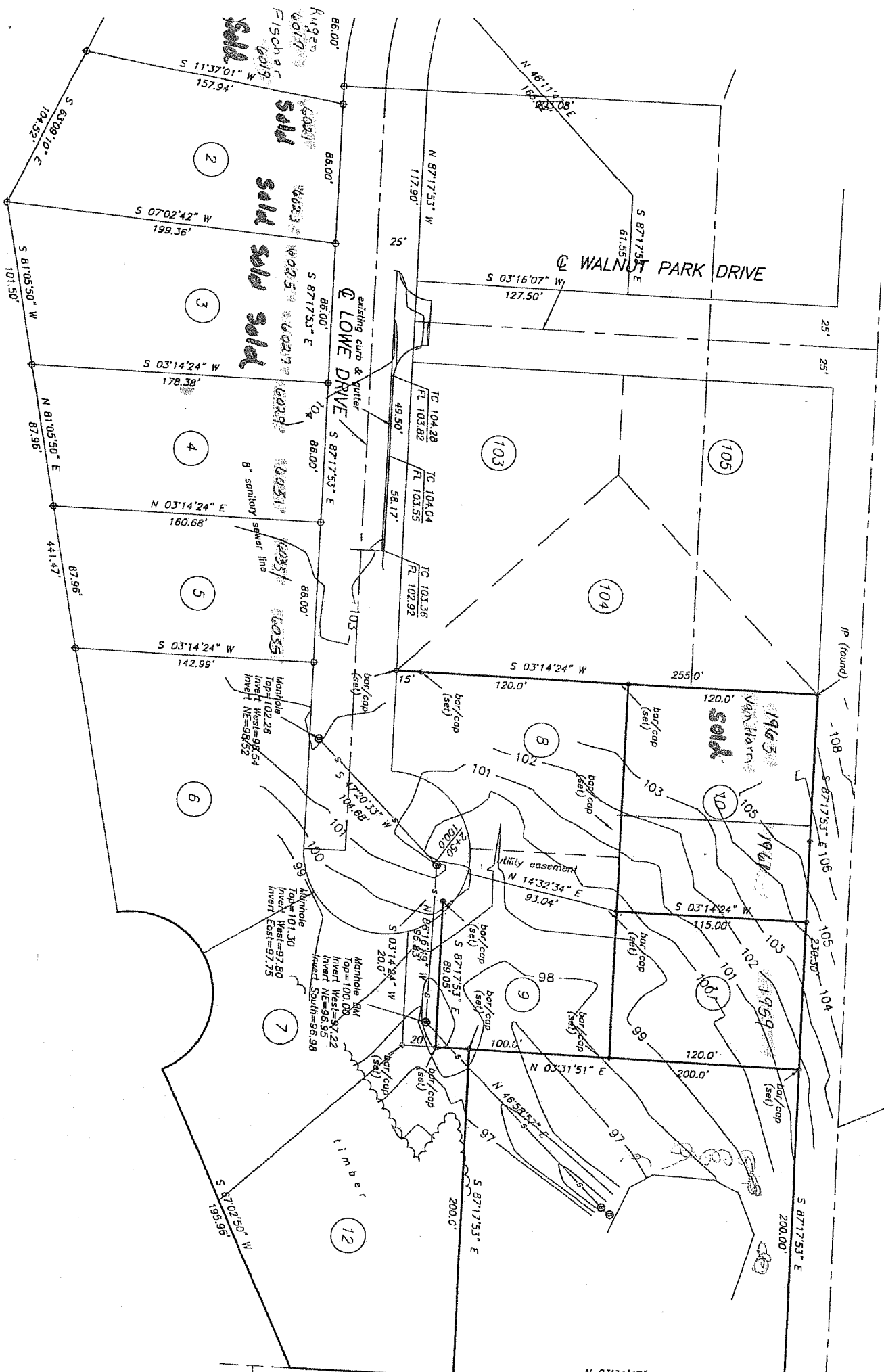

BILL NO. _____

ORDINANCE NO. _____

AN ORDINANCE AUTHORIZING TASK ORDER NUMBER TWO FOR TECHNICAL SUPPORT AND ENGINEERING SERVICES RELATED TO THE CENTRAL WASTEWATER TREATMENT PLANT EXPANSION.

WHEREAS, the City of Sedalia, Missouri has received Task Order #2 from Burns & McDonnell Engineering Company, Inc. for technical support and engineering services through application to the Missouri Department of Natural Resources for a State Revolving Fund Loan related to the Central Wastewater Treatment Plant expansion; and

WHEREAS, under the attached Task Order #2, the City of Sedalia, Missouri shall pay the sum and amount of One Hundred Forty-One Thousand Six Hundred Eighty-Nine Dollars (\$141,689.00) to Burns & McDonnell Engineering Company, Inc. for said services as more fully described in the proposed Task Order #2 attached to this Ordinance and incorporated by reference herein.

NOW THEREFORE, BE IT ORDAINED BY THE COUNCIL OF THE CITY OF SEDALIA, MISSOURI, as follows:

Section 1. The Council of the City of Sedalia, Missouri hereby approves and accepts Task Order #2 by and between the City of Sedalia, Missouri and Burns & McDonnell Engineering Company, Inc. attached hereto in substantively the same form and content as it has been proposed.

Section 2. The City Administrator is authorized and directed to execute and the City Clerk is hereby authorized and directed to attest and fix the seal of the City of Sedalia, Missouri on the Task Order in substantively the same form and content as it has been proposed.

Section 3. The City Clerk is hereby directed to file in his office a duplicate or copy of Task Order after it has been executed by the parties or their duly authorized representatives.

Section 4. This ordinance shall be in full force and effect from and after its passage and approval.

Read two times by title, copies of the proposed ordinance having been made available for public inspection in the City Clerk's Office prior to the time the bill is under consideration by the Council and passed by the Council of the City of Sedalia, Missouri this 18th day of December, 2023.

Presiding Officer of the Council

Approved by Mayor of said City this 18th day of December, 2023.

Andrew L. Dawson, Mayor

ATTEST:

Jason S. Myers, City Clerk

MEMO

TO: Kelvin L. Shaw, City Administrator
Matthew Wirt, Assistant City Administrator
Jason Myers, City Clerk

FROM: Christopher R. Davies, Public Works Director *EN for Chris Davies*

**SUBJECT: TASK ORDER NO.2 – TECHNICAL SUPPORT TO CITY OF
SEDALIA FOR APPLICATION TO THE MISSOURI
DEPARTMENT OF NATURAL RESOURCES FOR STATE
REVOLVING FUND LOAN FOR THE CENTRAL
WASTEWATER TREATMENT PLANT EXPANSION**

Background:

The City of Sedalia, in October 2022, advertised for Engineering Services, via a RFQ process following the procurement of engineering services in accordance with sections 8.285 through 8.291, RSMo. On or about December 2022, City Council approved Burns & McDonnell Engineering Company, Inc. (Burns & McD) to provide that service.

The City of Sedalia is under a consent order from MoDNR for both the North and Central Wastewater Treatment plants. The original concept was to upgrade specific portions of the Central WWTP to bring the plant into compliance; the North WWTP concept was to build a new plant north of the existing plant.

In reviewing past documents and concepts, staff made a recommendation to look at an alternative: the concept of combining both the “new” North WWTP and the Central WWTP into one (1) plant at the site of the existing plant. Once staff felt this was a viable option we worked through the concept with Burns & McD. Our next step was to bring the concept to MoDNR and review the process and concept to see if we had missed any key points. MoDNR felt this was a good way to proceed. The key benefits to this option are: 1) potential project savings of \$10M - \$15M, 2) reducing the number of WWTP, and 3) saving approximately 1 -2 years of time.

The City was also in the process of applying for State Revolving Funds Loan, which is a low interest loan program for large projects in the water and wastewater field. Applications for SRF funding are due March 1 of each year.

Since the original concept of a new plant and moving to a consolidation of plants, this would require some additional work by our engineer, which was outside of any existing scope of work.

Discussion:

In working with both Burns & McD and MoDNR, we have prepared a scope of work (Task Order No. 2) which engages Burns & McD in assisting the City of Sedalia in applying for SRF Funding and making application by the deadline of March 1, 2024. The scope of work includes the following major components: 1) Project Management, 2) Antidegradation Report, 3) Site Evaluation, 4) Feasibility Study, and 5) Assistance in applying for all appropriate grants and loans through MoDNR.

Recommendation:

City staff recommends the City Council approved the Engineer-Owner Agreement (Task Order No. 2) for the assistance with Technical Support to apply to MoDNR for SRF funding.



**TASK ORDER FOR
ENGINEER-OWNER AGREEMENT**

Exhibit A - Task Order No. 2

This Task Order is entered into and authorized by Owner this ____ day of _____, 2023, by and between the City of Sedalia (hereinafter called OWNER) and Burns & McDonnell Engineering Company, Inc. (hereinafter called ENGINEER).

The parties agree that the ENGINEER shall perform the following Services in accordance with the terms of the Engineer-Owner Agreement dated February 22, 2023:

1. Scope of Services:

ENGINEER will assist OWNER with technical support for application to the Missouri Department of Natural Resources for State Revolving Fund Loan for the Central Wastewater Treatment Plant Expansion. As part of the technical support for the application, a Feasibility Study will be developed for the proposed project scope. The scope of this work will focus on the consolidation of the North Wastewater Treatment Plant and Central Wastewater Treatment Plant at the Central Wastewater Treatment Plant site. The proposed scope includes evaluation of the expansion of the Central Wastewater Treatment Plant to a rated capacity of five (5) million gallons per day, associated decommissioning of the North Wastewater Treatment Plant, and conveyance of flows from the North Wastewater Treatment Plant to the Central Wastewater Treatment Plant site. Storage to accommodate peak wet weather flows will be maintained as currently configured at the North Wastewater Treatment Plant Site and a new peak wet weather storage basin will be sited adjacent to the Central Wastewater Treatment Plant site. Schematic routing and preliminary confirmation to convey flow from the North Wastewater Treatment Plant to the Central Wastewater Treatment Plant tributary collection system will be evaluated. Exhibit B provides a defined scope of services for this Task Order.

2. Compensation:

A. Amount of Payment:

1. For Services performed, OWNER shall pay ENGINEER the lump sum amount of One hundred Forty-one Thousand Six Hundred Eighty-nine dollars (\$141,689.00).
2. For additional, reduced, or changed Scope of Services, the amount of payment shall be adjusted on a mutually agreeable lump sum basis.

B. Statements:

1. Monthly statements will be submitted by ENGINEER to OWNER. Statements will be based on ENGINEER's estimated percent of Services completed at the end of the preceding month.

3. Time of Service:

- A. ENGINEER shall proceed with providing the services set forth herein within approximately 5 days of the execution of this Task Order. It is anticipated that these services shall be completed within 90 days of execution of this Task Order.
- B. Completing the services within the above time frame is contingent upon the timely receipt of required information, approvals, and/or reviews.

4. Other Terms:

- A. The terms of this Task Order supersede any contrary terms of the Engineer-Owner Agreement.

IN WITNESS WHEREOF, the parties have made and executed this TASK ORDER as of the day and year first above written.

OWNER: City of Sedalia, Missouri

**ENGINEER: Burns & McDonnell
Engineering Company, Inc.**

By: _____

By: _____

Name: Kelvin L. Shaw, CPA

Name: Patrick Clifford, P.E.

Title: City Administrator

Title: Global Practice Manager



Exhibit B – Task Order No. 2

**City of Sedalia, Missouri
Central Wastewater Treatment Plant Expansion - Feasibility Study**

Scope of Services: ENGINEER will assist OWNER with technical support for application to the Missouri Department of Natural Resources (DNR) for State Revolving Fund Loan for the Central Wastewater Treatment Plant Expansion. As part of the technical support for the application, a Feasibility Study will be developed for the proposed project scope. The scope of this work will focus on the consolidation of the North Wastewater Treatment Plant and Central Wastewater Treatment Plant at the Central Wastewater Treatment Plant site. The proposed scope includes evaluation of expansion of the Central Wastewater Treatment Plant to a rated capacity of five (5) million gallons per day and associated decommissioning of the North Wastewater Treatment Plant and conveyance of flows from the North Wastewater Treatment Plant to the Central Wastewater Treatment Plant site. Storage to accommodate peak wet weather flows will be maintained as currently configured at the North Wastewater Treatment Plant Site and a new peak wet weather storage basin will be sited adjacent to the Central Wastewater Treatment Plant site. Schematic routing and preliminary confirmation to convey flow from the North Wastewater Treatment Plant to the Central Wastewater Treatment Plant tributary collection system will be evaluated. The following will be referenced for supporting information including treatment alternatives evaluation, existing conditions, and future projections:

Wastewater Facilities Evaluation – June 2022 (Burns & McDonnell)

Wastewater Master Plan – April 2022 (Burns & McDonnell)

Central WWTP Improvements Phase 1 – November 2022 (Burns & McDonnell)

Antidegradation Review Report – September 2022 (Burns & McDonnell)

Task 1 – Project Management

1. Project Administration
 - a. The Engineer shall prepare a monthly status report and invoices and will monitor project budget, labor hours expended and schedule throughout the project. Monthly status reports will describe the work completed during the previous month, anticipated work for the following month, current budget and schedule status, and any project issues requiring discussion or resolution.
2. Progress Meetings
 - a. Engineer shall conduct one (1) virtual and one (1) in-person progress meetings with Owner to provide updates on work progress, budget and schedule status, current issues, and/or variance in potential scope of work. Engineer will draft meeting minutes and provide to Owner for review and approval.
3. Project QA/QC Activities
 - a. The Engineer will perform internal quality assurance and quality control on project deliverables.



Task 2 – Antidegradation Report

1. Evaluation and Review

- a. Evaluation of discharge options on a pollutant-by-pollutant basis relative to determining whether the Antidegradation approach will be significantly or minimally degrading.
- b. Identify and assess no-discharge options, minimally degrading, and significantly degrading alternatives with consideration for each pollutant of concern; these options will be reused from the North Wastewater Treatment Plant Anti-degradation review. One option for consolidation at the Central Wastewater Treatment Plant will be evaluated. Prepare an evaluation of alternatives to the proposed discharge. These alternatives are compared in terms of practicability, economic efficiency and affordability.
- c. Determine the Base Case Effluent Limits – Identify a reliable treatment design to be the Base Case that will meet the minimum water quality requirements of the receiving water. All pollutants of concern will be identified to determine minimum water quality requirements including considerations for the current North Plant pollutants of concern.
- d. Conduct an Alternatives Analysis – Preliminary assessment will be completed to review three alternatives. Alternatives include no discharge (copied from North Wastewater Treatment Plant Anti-degradation review), construction of a new North Wastewater Treatment plant (copied from North Wastewater Treatment Anti-degradation review), and a new consolidated treatment facility at the Central Wastewater Treatment Plant resulting in decommissioning the existing North Wastewater Treatment Plant. Flow schematics, cost estimates, and present worth calculations will be developed for each alternative. The preferred alternative will be selected.
- e. Develop Effluent Limits for Discharge Options – Effluent limits for all discharge will be established. For pollutants shown to be non-degrading using the method, effluent limits shall reflect the maintenance of pollutant concentrations. For pollutants that are degrading, the effluent limits shall reflect the concentrations that can be reliably met by the preferred alternative.
- f. Determine Social and Economic Impacts – Identify the affected community, identify relevant factors that characterize the social and economic conditions of the affected community and describe the important social and economic development associated with the project.

2. Report Development

- a. Draft Antidegradation Review Report – A draft Antidegradation report will be developed to summarize the project background and the evaluation approach. The draft will be provided to the OWNER for review and comment.
- b. Final Antidegradation Review Report – OWNER comments will be incorporated into the Final Report for inclusion in the Feasibility Study.
- c. Complete Antidegradation forms and other requirements – complete associated forms and requirements including the natural heritage review, and antidegradation tier form. Provide to OWNER as included in the Antidegradation Review Report.
- d. OWNER will be responsible for submitting Antidegradation Review Report to DNR and for any associated fees.
- e. Correspond with the DNR as necessary; up to eight hours of correspondence is included as part of the work.



Task 3 – Environmental Review

TASK 3 IS NOT INCLUDED IN THE INITIAL SCOPE AND FEE; SCOPE, FEE, AND SCHEDULE WILL BE FINALIZED BASED ON FINDINGS FROM THE FEASIBILITY STUDY. AN AMENDMENT WILL BE ISSUED PRIOR TO PROCEEDING WITH TASK 3.

1. Environmental Assessment and Coordination
2. Environmental Field Investigations

Task 4 – Site Evaluation

1. Review location of proposed projects in terms of accessibility, topographic restrictions, wind direction, potential noise and odors, and siting of proposed improvements. ENGINEER will develop concept site layout figures for the proposed Central Equalization Basin, Central Plant expansion, and North Lift Station and pipe alignment.
2. Coordination of the Geohydrologic Evaluation – ENGINEER will coordinate with DNR to complete a geological site evaluation to determine geologic information, depth of bedrock, karst features, or other geological considerations of significance to the project. ENGINEER will attend a kickoff meeting and site visit to review site conditions and proposed improvements.
3. Floodplain Analysis – Engineer will acquire the FEMA effective floodplain model and Flood Insurance Rate map data to analysis the floodplain condition at the Central Wastewater Treatment Facility site. The FEMA model will be reviewed to determine the impacts to the floodplain based on proposed expansion at the Central Plant. Up to three scenarios will be simulated in the floodplain model. Engineer will determine if there are viable mitigation strategies to limit impacts to the floodplain. Permitting options will be evaluated and a recommended feasible floodplain development plan will be developed. Engineer will determine an appropriate elevation for the proposed expansion to keep facilities in operation for the 25 year flood and protect infrastructure from damage during the 100 year flood event.

Task 5 –Central Wastewater Treatment Plant Equalization Basin Evaluation

TASK 5 IS NOT INCLUDED IN THE INITIAL SCOPE AND FEE; SCOPE, FEE, AND SCHEDULE WILL BE FINALIZED BASED ON FINDINGS FROM THE FEASIBILITY STUDY. AN AMENDMENT WILL BE ISSUED PRIOR TO PROCEEDING WITH TASK 5.

1. Lagoon Closure Plan –
2. Field Investigation and Sampling –

Task 6 – Feasibility Study

ENGINEER will draft a Feasibility Study report for the OWNER to submit in conjunction with the associated SRF application. The Feasibility Study will provide schematic design for the North Pump Station, force main, collection system upgrades, and flow equalization for the Central Wastewater Treatment Plant Expansion. A schematic design to consolidate the discharge from the North Wastewater Plant and the Central Wastewater Plant to a single facility at the Central Wastewater Treatment Plant will be developed. The opinion of costs for the proposed project will be provided.

1. Previous wastewater master plan reports will be utilized to provide basic information in the study of the planning and service area, population projections and proposed planning period.
2. Alternatives evaluation will be completed utilizing previous reports which included a no-discharge alternative and a new plant to replace the existing North Wastewater Treatment Plant. Schematic design will be developed to evaluate an additional alternative to combine the



North and Central Wastewater Treatment Plants to a single facility at the Central Wastewater Treatment Plant site. A recommended project alternative will be established. Previous master plan will be referenced in relation to the evaluation of the existing wastewater facilities condition.

3. A schematic design of the proposed sewer collection system infrastructure associated with routing flow from the existing North treatment plant to the Central Plant will be developed. Easements and improvements to the existing collection system will be identified.
4. Storage to accommodate peak wet weather flows will be maintained as currently configured at the North Wastewater Treatment Plant Site and a new peak wet weather storage basin will be sited adjacent to the Central Wastewater Treatment Plant site. The existing collection system model will be utilized to verify the volume of the proposed storage basin. The model will be used to evaluate the management of wet weather flow conditions for both the north and central sewer basins. Previous master plan report will be referenced to address inflow and infiltration analysis and evaluation.
5. Wastewater strength received at the North Wastewater Treatment Plant and Central Wastewater Treatment Plant periodically exceeds typical domestic strength. Basis for design of the consolidated Central Wastewater Treatment Plant will consider typical domestic strength wastewater (medium strength, as defined in the fifth edition of *Wastewater Engineering Treatment and Resource Recovery* by Metcalf & Eddy). Implementation and governance of pretreatment program by the OWNER will serve to regulate and reduce industrial contributions in lieu of planning and construction of a municipal facility to receive and treat industrial strength waste. OWNER will conduct laboratory analysis to characterize influent (upstream of the primary clarifiers) to support development of biological calculations to supplement historical plant performance data for the North Wastewater Treatment Plant and the Central Wastewater Treatment Plant. The data collection will occur over fourteen consecutive days and will consist of the following parameters: (1) influent and effluent flow, (2) influent chemical oxygen demand (COD), (3) influent biochemical oxygen demand (BOD), (4) influent soluble BOD, (5) influent total Kjeldahl nitrogen, (6) influent ammonia, (7) influent nitrate and nitrite, (8) influent total phosphorus, (9) influent orthophosphate, (10) influent total suspended solids (TSS), (11) influent volatile suspended solids, (12) influent pH, (13) influent alkalinity, (14) RAS flow, (15) WAS flow. OWNER shall note any operational irregularities including return flow from extraneous flow basins, solids handling filtrate, or otherwise impactful conditions. OWNER shall provide additional Daily Monitoring Report data from previous years (2021-2023).

Task 7 – Facility Plans

TASK 7 IS NOT INCLUDED IN THE INITIAL SCOPE AND FEE; SCOPE, FEE, AND SCHEDULE WILL BE FINALIZED BASED ON FINDINGS FROM THE FEASIBILITY STUDY. AN AMENDMENT WILL BE ISSUED PRIOR TO PROCEEDING WITH TASK 7.

1. Facility Plan No. 1: North Lift Station, Force Main, and New Equalization Basin
2. Facility Plan No. 2: Central Wastewater Treatment Plant Expansion



Task 8 – Clean Water State Revolving Loan Fund Application

Engineer will provide assistance in application for the Clean Water State Revolving Loan Fund. Up to three (3) applications may be made to maximize grant funding opportunities. The applications will include the following:

1. CWSRF with Emerging Contaminant Grant: pending sampling at the existing Central Wastewater Treatment Plant flow equalization basin, accumulated sludge may contain emerging contaminants. If emerging contaminants are present, the Engineer will provide technical assistance included in Task 5 in application for the Emerging Contaminant Grant as part of a CWSRF application.
2. CWSRF with Affordability Grant: pending final determination of capital cost and implementation schedule, the Engineer will provide technical assistance included in Task 6 in application for the Affordability Grant as part of the CWSRF application.
3. CWSRF with Water Quality Grant: based on discussion with DNR staff, a Water Quality Grant may be applicable to the project. Engineer will provide technical assistance included in Task 6 in application for the Water Quality Grant as part of the CWSRF application.